

Drive^{IT} Low Voltage AC Drives

Technical Catalogue

ACS 100, ACS 140, ACS 160, ACS 400, 0.12 kW - 37 kW

Related tools and accessories

efesotomasyon.com



Instant ordering and advice

Easy to pay, most credit cards accepted

Fast delivery within hours

Simple documentation easy to read

Support line

2 year worldwide warranty

The advertisement features a vertical column of six icons on the left side, each with a corresponding text block. The icons are: a handheld device for instant ordering, a Mastercard and Visa logo for payment, a white delivery van for fast delivery, a document for simple documentation, a globe with a hand for support, and a globe with a ribbon for warranty. The background of the advertisement is a photograph of an industrial facility with large ABB Drive IT units and two workers in hard hats reviewing documents.

Services

Nobody looks after you better. Every drive you buy comes with comprehensive support services from instant advice through fast delivery to worldwide warranty cover.

Buying a drive has never been so quick and easy.



...instant advice and ordering

Take advantage of our fast advice and ordering service by calling us on the telephone number shown on the back page.



...an easy way to pay

You can now call us with most major credit cards to get your drive in a matter of hours.



...a rapid delivery service

Once you have ordered your drive, we'll get it to you in a few hours, with remote locations taking just a little longer.



...simple documentation

We've cut the paper work! One instruction card tells you all you need to know to install and use your drive.



...round the clock help

Our 'SupportLine' answers any queries you may have about running your drives.



...worldwide warranty cover

We can support your drives globally through our network of ABB offices and local distributors in virtually every country.

Industrial^{IT} for drives	4
Energy Saving and Original Equipment Manufacturers	5
Drive^{IT} Low Voltage AC Drives	6
General Benefits	6 - 7
Application Macros	8
Features and Selection Guide	9
ACS 100 Micro Drive 0.12 - 2.2 kW	10
Technical Specification	11
Technical Data	12
Connection Examples	13
Options	14 - 16
ACS 140 Machinery Drive 0.12 - 2.2 kW	17
Technical Specification	18
Technical Data	19 - 20
Connection Examples	21
Options	22 - 24
ACS 160 Integral Drive 0.55 - 2.2 kW	25
Technical Specification	26
Technical Data	27
Connection Examples	27
Electro Magnetic Compatibility	28
Options	29 - 30
ACS 160 and Motor Combinations	31
Derating Information	31
Motor Technical Data	32 - 34
ACS 400 Standard Drive 2.2 - 37 kW	35
Technical Specification	36
Technical Data	37
Connection Examples	38
Options	39 - 44
Brake Options	45
Brake units and choppers	45
Start-up and Maintenance Tool	46
DriveWindow Light 2	46
Contact and web information	47

Industrial^{IT} for drives

As a key element of its business strategy, ABB has committed to a broad program of product development and positioning under the Industrial^{IT} umbrella. This initiative is geared towards increasing standardization of ABB products as the “building blocks” of larger solutions, while building in functionality that will allow multiple products to interact seamlessly as components of real-time automation and information systems.

At the product level ABB's Industrial IT architecture ensures that ABB products can interoperate perfectly. Only products that satisfy a complete list of requirements stipulated by Industrial IT are certified to bear the Industrial IT enabled symbol, a special mark that indicates that the product can be easily integrated into the Industrial IT architecture, in a “plug & produce” manner.

Standardization and an architecture based on open standards increase engineering efficiency, speed of implementation and quality. The final result is higher productivity and more output from your plant. Through versatile connectivity the drives made by ABB can be easily integrated with different process automation systems fulfilling the requirements of Industrial IT.

Our Drive^{IT} drive products provide the performance, energy savings and life extension that the customers have come to expect from ABB.



Energy Saving and Original Equipment Manufacturers

Energy Saving with Low Voltage AC Drives

Often considered only with larger motors, the energy saving feature of the AC drives is valid also in the low voltage range. Not having to run the motors at full speed all the time, one can obtain benefits in energy cost savings. In the ABB Low Voltage AC Drives, the losses in the drive itself are minimal and high switching frequencies result in low losses of the motor as well.

The energy saving potential of AC drives is highest in pump and fan applications, but also compressors, conveyors, lifts and many more applications may benefit from AC drive control. In HVAC systems, there are numerous low voltage motors driving pumps and fans. Controlling the speed of these motors according to the actual demand of water or air flow brings considerable energy savings, because motors are the dominant consumer of electric power in these systems. Improve your HVAC system efficiency with Low Voltage AC Drives.

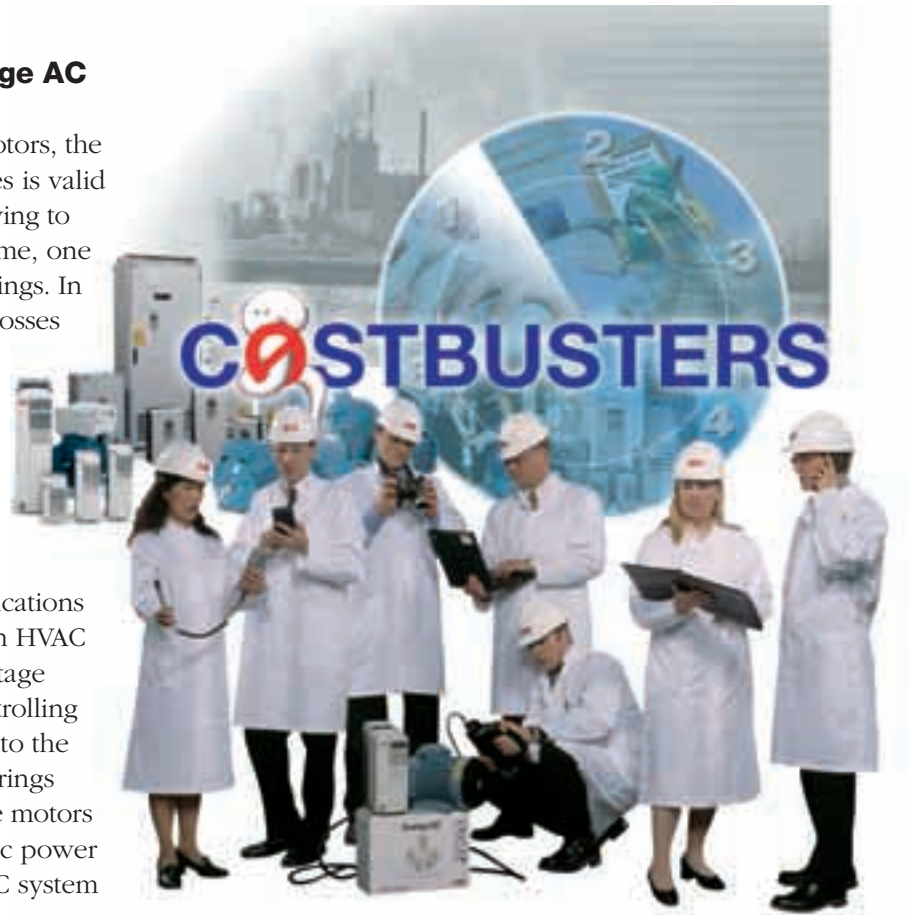

Call ABB Costbusters to audit the energy usage of your motors. With dedicated software, they will calculate how much energy and money you can save with AC drives. Or ask for a CD-ROM, containing calculation tools and 100 energy saving tips. These 100 tips are also available as a printed pocket guide.

OEM - Drives to provide solutions

ABB has in-depth experience of providing solutions for machine builders and system integrators. This drives expertise benefits both local and global OEMs (Original Equipment Manufacturers). OEM customers often have characteristics such as:

- Aiming to create a competitive advantage by using drives in an innovative way
- High purchase volume of motors or drives
- Working as a system integrator selling projects to one or multiple industries
- Need for a specific drive solution

When drives play an essential role in machinery, or in other devices incorporating drives, continuity in product quality, design, delivery and service is a must.



Example of OEM design. Integrated fan, motor and inverter in a single package.

efesotomasyon.com

Drive^{IT} Low Voltage AC Drives

General Benefits

Drive^{IT} Low Voltage AC Drives

Product types ACS 100, ACS 140, ACS 160 and ACS 400 covering 0.12 - 37 kW belong to the range of the Drive^{IT} Low Voltage AC Drives. All the Low Voltage AC Drives benefit from the same proven technology and reliability. They offer the benefits of efficient control to virtually every type of industrial process where AC motors are used. The Low Voltage AC Drives have an excellent track record and there are already hundreds of thousands of installed units.

A unique set of services is also included with these Low Voltage AC Drives to ensure that the entire process from drive selection to world-wide support and warranty is as straightforward as possible for the user.

Wide choice of mounting options

Catering for the different requirements of end users, panel builders and OEMs, the Low Voltage AC Drives provide several different ways of mounting: motor mounting, conventional wall mounting, time saving DIN-rail mounting and flange mounting. Mounting onto an external heatsink is also available. IP 54 or IP 65 enclosures are also available for operation in harsh industrial environments. Mounting options vary from product to product.

The newest Low Voltage AC Drive, ACS 160, can be retrofitted on the terminal box of a standard AC low voltage motor, combining the performance and reliability of a standard AC drive and the robustness of an industrial AC motor. Using a motor mounting kit, the ACS 160 can be quickly and easily retrofitted to most common AC motors, providing considerable savings in design, cabling and assembly costs.

EMC Compliant

The Low Voltage AC Drives range conforms to the European Union Electro Magnetic Compatibility directive, a requirement for CE marking. To decrease electromagnetic disturbances and harmonics, EMC filters and input/output chokes are available as options. These features make the Low Voltage AC Drives well suited for both residential and industrial installations.



The reliability of the drives in the Low Voltage AC Drives range makes these suitable for all types of continuous processes, such as pumping and mixing.

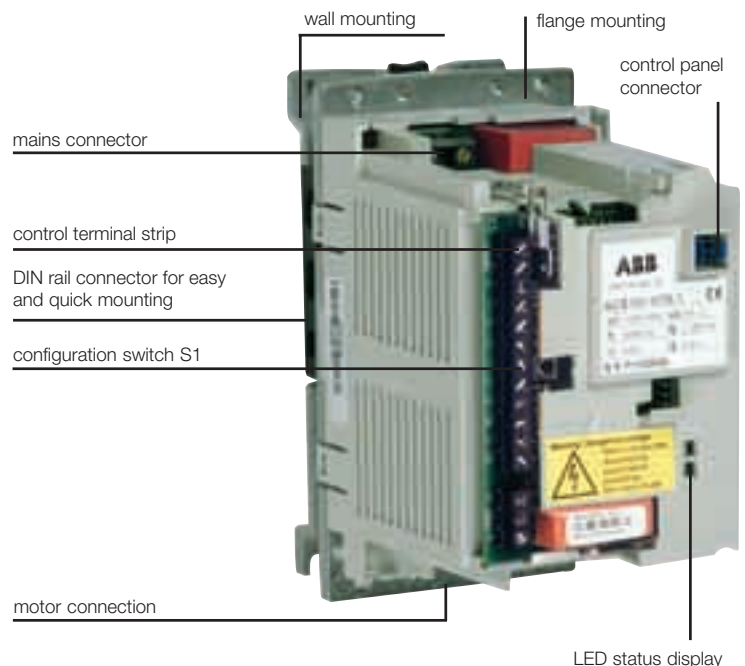

High repeatability for constant end product quality

High repeatability ensures constant product quality across a range of applications, and is one of the cornerstones in the design of the Low Voltage AC Drives. The very low variance in response time and accuracy enables control of processes within narrow tolerances whilst ensuring predictable behaviour of machinery. In addition, the serial communication feature along with the digital control interface maintains constantly high repeatability.



Repeatability is an essential feature in material handling and packaging applications. It is also one of the cornerstones in the design of the Low Voltage AC Drives.

Excellent features for material handling

Especially in material handling and packaging applications, where precise positioning of goods is essential, the high repeatability of the drives in the Low Voltage AC Drives range is a clear advantage. In addition, the seven pre-set speeds enable easy speed changes, when switching to a different size, weight or type of material. Features including up to 180% overloadability, PTC interface, built-in mechanical brake control and electrical braking produce an unbeatable combination for material handling applications. The ACS 160 Positioning macro together with an optional encoder even makes it possible to eliminate expensive PLCs in simple positioning applications.

Ideal solution for building automation

With features such as flying start, the Low Voltage AC Drives are a practical choice for many applications in building automation such as air handling. The built-in PID control with two



Intelligent building systems will benefit from Low Voltage AC Drives features, such as easy integration to building management systems and built-in PID control.

parameter sets keeps variables such as temperature, pressure, or humidity under control. The Low Voltage AC Drives are quiet in operation and therefore well suited for office and residential environments. The Low Voltage AC Drives feature displays that can be configured to directly indicate parameters such as the flow rate of a pumped fluid, for instance. LONWORKS® adapter or embedded Johnson Controls' N2 protocol are available for integration into building automation systems.

Integrated ABB drive and motor for easy commissioning and use

To make commissioning and use as easy as possible we offer a comprehensive range of integrated motor and drive packages. The motor and drive will then be delivered as an integrated, ready-to-use package. The motor and the drive are perfectly matched and can be used in basic applications without needing any further setting up. For more demanding applications, an optional IP 65 control panel can be used to select from a range of more advanced application macros.



Application Macros

What are application macros?

A wide selection of pre-set application macros have been created to ensure fast and easy commissioning of all ABB Low Voltage AC Drives.

With application macros you can set up your drive extremely fast for all the most common applications. And of course you can fine tune the drive operation by changing the pre-set parameters if needed.

By changing only one parameter all the drive's macro-specific parameters are automatically set with new pre-set values. The drive's I/O-terminals are also automatically configured to meet the demands set by your application.

All the application macros which can be used with ACS 100, ACS 140, ACS 160 and ACS 400 drives are listed below together with explanations.

The **Factory** application macro is intended for applications where the drive is used without a control panel, providing a general purpose I/O-configuration.

The **ABB Standard** (typically used in Europe) and the **3-wire** (typically used in the United States) application macros are configured for general purpose applications, and offer two additional pre-set speeds compared to the factory application macro.

The **Alternate** application macro has an I/O-configuration adopted to a sequence of DI-control signals used when alternating the direction of the drive.

The **Motor Potentiometer** application macro provides a cost-effective interface for PLCs that vary the speed of the drive using only digital signals.

The **Hand/Auto** application macro offers an I/O-configuration typically used in HVAC applications.

The **PID Control** application macro is intended for use with closed-loop control systems such as pressure and flow control.

The **Premagnetise** application macro enables rapid starting by eliminating the delay normally experienced while flux builds up in the motor.

The **Positioning** application macro is for simple positioning tasks. Default operation is appropriate for example for conveyor systems where items are moved a certain distance.

The **Pump and Fan Control (PFC)** application macro can drive a load such as a pump, fan or compressor station with one to four pumps, enabling speed control for one pump and on/off control for the others.

ACS 100



ACS 140



ACS 160



ACS 400



Features and Selection Guide

	200-240 V 0.12-2.2 kW	200-480 V 0.12-2.2 kW	380-480 V 0.55-2.2 kW	380-480 V 2.2-37 kW
	ACS 100	ACS 140	ACS 160	ACS 400
Functions				
Start; normal/flying/torque boost		■	■	■
Start; premagnetising		■	■	■
IR compensation	■	■	■	■
Stop; ramp/coasting	■	■	■	■
Stop; DC brake	■	■	■	■
DC hold	■	■	■	■
U/f -ratio; linear/square	■	■	■	■
Acceleration/deceleration 1 (s)	0.1 ... 1800	0.1 ... 1800	0.1 ... 1800	0.1 ... 1800
Acceleration/deceleration 2 (s)		0.1 ... 1800	0.1 ... 1800	0.1 ... 1800
S-ramp; fast/medium/slow	■	■	■	■
Preset speeds ¹⁾	■ 1	■ 7	■ 7	■ 7
Critical frequencies ¹⁾		■ 2	■ 2	■ 2
Slip compensation		■	■	■
Application Macros				
Factory	■	■	■	■
ABB Standard	■	■	■	■
3-wire	■	■	■	■
Alternate	■	■	■	■
Motor potentiometer		■	■	■
Hand/Auto Control		■	■	■
PID Control (process)		■	■	■
Premagnetise		■	■	■
Pump and Fan Control (PFC)				■
Positioning			■	
Protection, fault functions				
Overload protection	■	■	■	■
Stall protection		■	■	■
Output overcurrent	■	■	■	■
Output short circuit	■	■	■	■
Ground fault, motor cable	■	■	■	■
Underload			■	■
Network failure	■	■	■	■
Low input signal level (AI<min)	■	■	■	■
Panel fault	■	■	■	■
Overvoltage	■	■	■	■
Undervoltage	■	■	■	■
External fault		■	■	■
Automatic fault reset, undervoltage	■	■	■	■
Automatic fault reset, overvoltage, overcurrent, AI<min		■	■	■
Fault history ¹⁾	■ 1	■ 3	■ 3	■ 3
Supervision functions (programmable)²⁾				
Speed		■	■	■
Current		■	■	■
Torque		■	■	■
Output power		■	■	■
Reference setpoint		■	■	■

¹⁾ The number indicates the amount of different speeds / frequencies / faults.

²⁾ Many other signals can also be monitored, see the user's manual.

■ standard feature

ACS 100 Micro Drive

0.12 kW - 2.2 kW Supply Voltage 200 - 240 V

Unique features

- The plug and produce construction
- Easy and simple to use
- Many installation possibilities

More value for money

- Parameter copy
- Wide range of protection
- Fast and accurate control
- Fast and accurate I/O response
- Cost optimization without the panel

Mounting options

In addition to the conventional wall mounting and time-saving DIN rail mounting, the ACS 100 also offers flange-mounting. The heatsink is located outside the enclosure and hence the major share of the power loss is external to the enclosure.

Heatsinkless

In cases where space is a limitation, drives without a heatsink can be delivered as standard. The user has to provide an installation surface with sufficient cooling. For more information, please refer to the ACS 100 User's Manual.

Mounting options



Dimensions



ACS 100 Technical Specification

Mains connection

Power range: 0.12 - 2.2 kW

Voltage: 1-phase and 3-phase, 200 to 240 V, $\pm 10\%$

Frequency: 48 to 63 Hz

Power Factor: 0.98

Use 60°C rated power cable (75°C if T_{amb} above 45°C).

Max. wire sizes (mm²)

- 4 single core/torque 0.8 Nm

Motor connection

Voltage: 3-phase, from 0 to U_{SUPPLY}

Frequency: 0 to 300 Hz

Continuous loading capability (constant torque at a max. ambient temperature of 40°C):

Rated output current I_2 .

Overload capacity (at a max. ambient temp. of 40°C):

- at constant torque $1.5 \times I_{2N}$, for 1 minute every 10 minutes
- at constant torque $1.25 \times I_{2N}$, for 2 minutes every 10 minutes

Characteristic data for short-time, intermittent and periodic load cycles are available on request.

Switching frequency:

Standard 4 kHz, Low-noise 8 kHz, Silent 16 kHz

Acceleration time: 0.1 to 1800 s

Deceleration time: 0.1 to 1800 s

For max. motor cable lengths see p. 16.

Programmable control connections

Max. wire sizes (mm²)

- 0.5-1.5 (AWG 22...AWG 16)/torque 0.4 Nm

One analog input:

- Voltage signal: 0 (2) to 10 V, 200 k Ω single-ended
- Current signal: 0 (4) to 20 mA, 500 Ω single-ended
- Potentiometer reference value:
10 V $\pm 2\%$ max. 10 mA, 1 k $\Omega \leq R \leq 10$ k Ω
- Response time: ≤ 60 ms
- Resolution: 0.1%
- Accuracy: $\pm 1\%$

Auxiliary voltage: 12 V DC, max. 100 mA

Three digital inputs:

- 12 V DC with internal or 12 V ... 24 V DC with external supply, PNP and NPN
- Input impedance: 1.5 k Ω
- Response time: ≤ 9 ms

One fault relay:

- Switching voltage: 12 to 250 V AC or max 30 V DC/0.5 A
- Maximum continuous current: 10 mA to 2 A

Serial communication for the control panel:

Modbus protocol

Protection limits

Overvoltage

- Running V DC: 420 (corr. to 295 V input)
- Start inhibit V DC: 390 (corr. to 276 V input)

Undervoltage

- Running V DC: 200 (corr. to 142 V input)
- Start inhibit V DC: 230 (corr. to 162 V input)

Environmental limits

Ambient temperatures:

- Output current = I_2 , $f_{switch} = 4$ kHz: 0 to 40°C
- Output current = $0.8 \cdot I_2$, $f_{switch} = 4$ kHz: 40 to 50°C
- Output current = I_2 , $f_{switch} = 8$ kHz: 0 to 30°C
- Output current = $0.9 \cdot I_2$, $f_{switch} = 8$ kHz: 30 to 40°C
- Output current = $0.75 \cdot I_2$, $f_{switch} = 16$ kHz: 0 to 30°C

Altitude:

- Output current = I_2 : 0 to 1000 m
- Output current reduced by 1% per 100 m over 1000 m to 2000 m

Relative humidity: lower than 95%
(without condensation)

Protection class: IP 20

Paint colour: NCS 1502-Y, RAL 9002, PMS 420 C

Contamination levels: no conductive dust, corrosive liquids or gases (IEC 721-3-3).

Product compliance

- Low Voltage Directive 73/23/EEC with supplements
- EMC Directive 89/336/EEC with supplements
- Quality assurance system ISO 9001 and ISO 14001
- CE, UL, ULc and C-Tick approvals

Options

- Control panel
- Extension cable 3 m with IP 65 Kit for control panels PEC-98-0008
- EMC IP 20 input filters
- Braking units and choppers
- Input and output chokes
- NEMA 1/ IP 21 Installation kits

ACS 100 Technical Data

0.12 kW - 2.2 kW Supply Voltage 200 - 240 V ± 10%

1-phase supply with heatsink

Type code	Nominal motor $P_N^{2)}$ kW	Nominal ratings			Max. output current A	Over- current (peak) A	Over- temp. (heat sink) °C	Line fuse ¹⁾ A	Power losses	
		Frame size/ weight kg	Input current I_{1N} A	Output current I_{2N} A					Power circuit W	Control circuit W
ACS 101-K18-1	0.12	A/0.9	2.7	1.0	1.5	3.2	90	6	7	8
ACS 101-K25-1	0.18	A/0.9	4.4	1.4	2.1	4.5	90	6	10	10
ACS 101-K37-1	0.25	A/0.9	5.4	1.7	2.6	5.5	90	10	12	12
ACS 101-K75-1	0.37	A/0.9	6.9	2.2	3.3	7.1	90	10	13	14
ACS 101-1K1-1	0.55	A/0.9	9.0	3.0	4.5	9.7	90	10	19	16
ACS 101-1K6-1	0.75	B/1.2	10.8	4.3	6.5	13.8	90	16	27	17
ACS 101-2K1-1	1.1	C/1.6	14.8	5.9	8.9	19.0	95	16	39	18
ACS 101-2K7-1	1.5	C/1.6	18.2	7.0	10.5	23.5	95	20	48	19
ACS 101-4K1-1	2.2	D/1.9	22.0	9.0	13.5	34.5	95	25	70	20

1-phase supply heatsinkless

Type code	Nominal motor $P_N^{2)}$ kW	Nominal ratings			Max. output current A	Over- current (peak) A	Over- temp. (heat sink) °C	Line fuse ¹⁾ A	Power losses	
		Frame size/ weight kg	Input current I_{1N} A	Output current I_{2N} A					Power circuit W	Control circuit W
ACS 101-H18-1	0.12	H/0.8	2.7	1.0	1.5	3.2	90	6	7	8
ACS 101-H25-1	0.18	H/0.8	4.4	1.4	2.1	4.5	90	6	10	10
ACS 101-H37-1	0.25	H/0.8	5.4	1.7	2.6	5.5	90	10	12	12
ACS 101-H75-1	0.37	H/0.8	6.9	2.2	3.3	7.1	90	10	13	14
ACS 101-1H1-1	0.55	H/0.8	9.0	3.0	4.5	9.7	90	10	19	16
ACS 101-1H6-1	0.75	H/0.8	10.8	4.3	6.5	13.8	90	16	27	17

3-phase supply with heatsink

Type code	Nominal motor $P_N^{2)}$ kW	Nominal ratings			Max. output current A	Over- current (peak) A	Over- temp. (heat sink) °C	Line fuse ¹⁾ A	Power losses	
		Frame size/ weight kg	Input current I_{1N} A	Output current I_{2N} A					Power circuit W	Control circuit W
ACS 103-K75-1	0.37	A/0.8	3.2	2.2	3.3	7.1	90	6	13	14
ACS 103-1K1-1	0.55	A/0.8	4.2	3.0	4.5	9.7	90	6	19	16
ACS 103-1K6-1	0.75	B/1.1	5.3	4.3	6.5	13.8	90	6	27	17
ACS 103-2K1-1	1.1	C/1.5	7.2	5.9	8.9	19.0	90	10	39	18
ACS 103-2K7-1	1.5	C/1.5	8.9	7.0	10.5	23.5	95	10	48	19
ACS 103-4K1-1	2.2	D/1.8	12.0	9.0	13.5	34.5	95	16	70	20

¹⁾ Fuse type: UL class CC or T. For non-UL installations IEC269 gG.

²⁾ P_N rated motor power. The power ratings in kW apply to most 2- and 4-pole IEC 34 motors. The current ratings are the same regardless of supply voltages. The rated current of the ACS 100 drive must be higher than or equal to the rated motor current to achieve the rated motor power given in the table.

ACS 100 Connection Examples

These connections are shown as examples only.
Please refer to the ACS 100 User's Manual for more detailed information.

DI configuration ABB standard

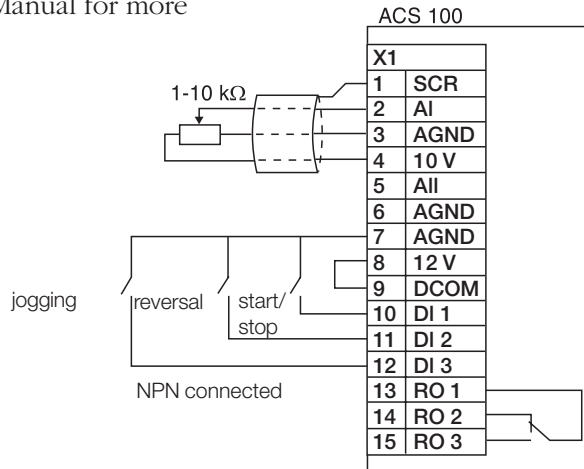

DI configuration 3-wire

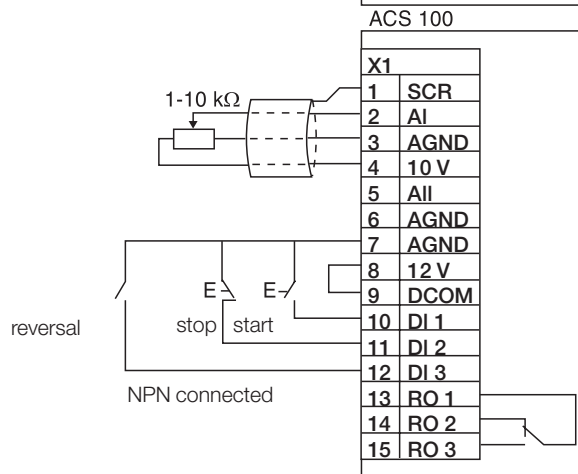

Frequency reference value from an external current source

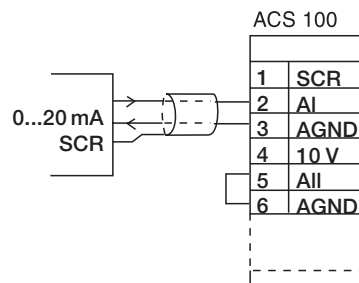

ACS 100 Options



Control Panel

Type code: ACS 100 - PAN

ACS 100 drives can be bought with or without a detachable control panel. If you prefer to buy the drive without the control panel we still offer you a chance to have the panel as an option. Using the control panel, parameters can be exchanged between two ACS 100 drives. This is called parameter upload/download procedure.

Panel Extension Cable Kit

Type code: PEC-98-0008

This option includes a gasket, a 3 m connection cable for control panels, fixing material for the cables and a drilling jig. With this kit IP 65 protection class is achieved.

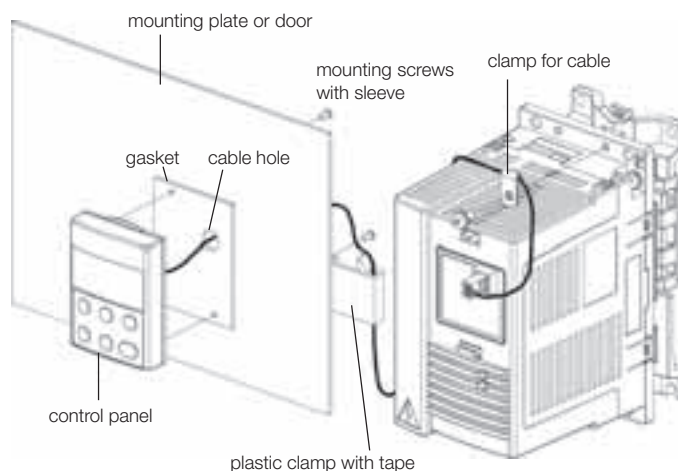
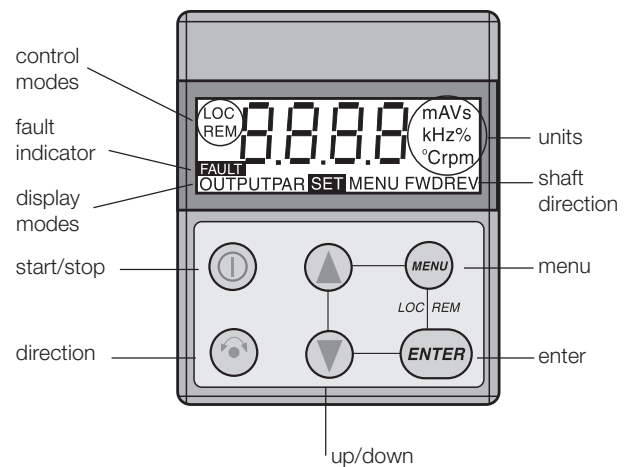

ACS 100 Options

EMC Filters

Instructions to comply with EN61800-3:

To comply with:

- **1st Environment, unrestricted** distribution, please contact your ABB distributor.
- **1st Environment, restricted** distribution, always use optional RFI filter as specified in the table below.

To comply with:

- **2nd Environment, unrestricted** distribution, always use optional RFI filter as specified in the table below
- **2nd Environment, restricted** distribution, always use optional RFI filter as specified in the table below. If RFI filters are to be avoided, an EMC plan has to be created between the customer and the sales person.

1-phase supply voltage 200 - 240 V, 0.12 - 2.2 kW

Type code	Filter type	Max. motor cable length m						Dimensions			
		Switching frequency						A mm	B mm	C mm	D mm
		1 st environment			2 nd environment						
4 kHz	8 kHz	16 kHz	4 kHz	8 kHz	16 kHz						
ACS 101-K18-1, -H18-1	ACS 100/140-IFAB-1	30	20	10	50	50	10	81	186	191	42
ACS 101-K25-1, -H25-1	ACS 100/140-IFAB-1	30	20	10	50	50	10	81	186	191	42
ACS 101-K37-1, -H37-1	ACS 100/140-IFAB-1	30	20	10	50	50	10	81	186	191	42
ACS 101-K75-1, -H75-1	ACS 100/140-IFAB-1	30	20	10	75	75	10	81	186	191	42
ACS 101-1K1-1, -1H1-1	ACS 100/140-IFAB-1	30	20	10	75	75	10	81	186	191	42
ACS 101-1K6-1, -1H6-1	ACS 100/140-IFAB-1	30	20	10	75	75	10	81	186	228	42
ACS 101-2K1-1	ACS 100/140-IFCD-1	30	20	10	75	75	10	81	286	211	42
ACS 101-2K7-1	ACS 100/140-IFCD-1	30	20	10	75	75	10	81	286	211	42
ACS 101-4K1-1	ACS 100/140-IFCD-1	30	20	10	75	75	10	81	286	218	42

RFI filter type code ACS 100 -FLT-C allows you to use longer motor cables. Please contact your ABB distributor. IFAB, IFCD and FLT-C filters with protection class IP 20.

Note! With types ACS...H mount the filter next to the drive.

3-phase supply voltage 200 - 240 V, 0.37 - 2.2 kW

Use EMC filter type ACS140-FLT-C with all ACS103-xKx-1 converter types. Maximum motor cable length is 100 m in 1st Environment, restricted distribution with 4 kHz and 8 kHz switching frequency. For ACS103-4K1-1 with EMC filter the maximum continuous load is 70% of nominal.

NEMA 1/ IP 21 Installation Kit

Type code: NEMA 1/ IP 21

With this installation kit NEMA 1/ IP 21 protection class is achieved for ACS 100 and for the EMC filter, if the filter is attached directly to the drive.

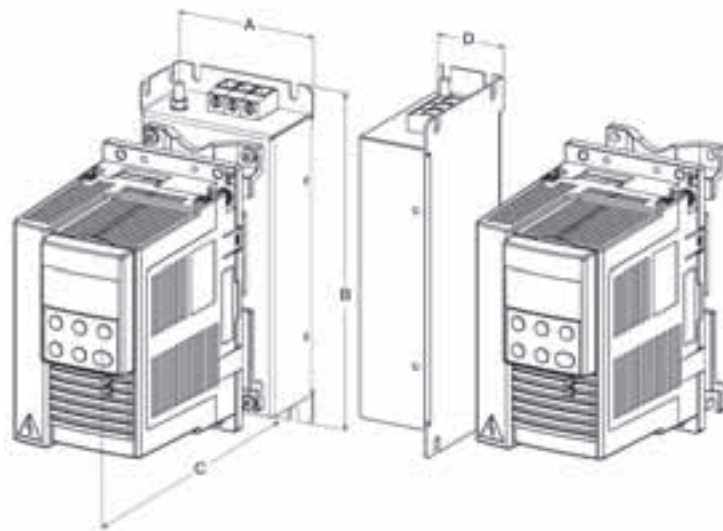

Input and Output Chokes

Output chokes are used when motor cables above normal length are required. This is possible because the output choke reduces capacitive currents and voltage reflections. The maximum switching frequency with output chokes is 4 kHz. Please note also your local EMC regulations.

Optional input chokes can be used with the ACS 100 in case voltage fluctuation problems occur in the supply net. The chokes eliminate converter trips caused by overvoltage spikes. At the same time chokes reduce line harmonics and therefore help to prevent other sensitive equipment in the same net from tripping.

Type code	Choke type		Max. motor cable length	
	Input choke	Output choke	with choke ¹⁾ m	without choke ¹⁾ m
1-phase Supply Voltage 200 - 240 V, 0.12 - 2.2 kW				
ACS 101-K18-1	SACL21	ACS-CHK-B3	75	50
ACS 101-K25-1	SACL21	ACS-CHK-B3	75	50
ACS 101-K37-1	SACL21	ACS-CHK-B3	75	50
ACS 101-K75-1	SACL21	ACS-CHK-B3	110	75
ACS 101-1K1-1	SACL21	ACS-CHK-B3	110	75
ACS 101-1K6-1	SACL22	ACS-CHK-B3	110	75
ACS 101-2K1-1	SACL22	ACS-CHK-C3	110	75
ACS 101-2K7-1	SACL23	ACS-CHK-C3	110	75
ACS 101-4K1-1	SACL24	ACS-CHK-C3	110	75
3-phase Supply Voltage 200 - 240 V, 0.37 - 2.2 kW				
ACS 103-K75-1	ACS-CHK-B3	ACS-CHK-B3	110	75
ACS 103-1K1-1	ACS-CHK-B3	ACS-CHK-B3	110	75
ACS 103-1K6-1	ACS-CHK-B3	ACS-CHK-B3	110	75
ACS 103-2K1-1	ACS-CHK-B3	ACS-CHK-C3	110	75
ACS 103-2K7-1	ACS-CHK-C3	ACS-CHK-C3	110	75
ACS 103-4K1-1	ACS-CHK-C3	ACS-CHK-C3	110	75
1-phase Supply Voltage 200 - 240 V, 0.12 - 0.75 kW / Heatsinkless				
ACS 101-H18-1	SACL21	ACS-CHK-B3	75	50
ACS 101-H25-1	SACL21	ACS-CHK-B3	75	50
ACS 101-H37-1	SACL21	ACS-CHK-B3	75	50
ACS 101-H75-1	SACL21	ACS-CHK-B3	110	75
ACS 101-1H1-1	SACL21	ACS-CHK-C3	110	75
ACS 101-1H6-1	SACL21	ACS-CHK-C3	110	75

¹⁾ Without EMC filter

Technical data

Choke type	L/mH	Dimensions H x W x D mm	Weight kg	Max. cable mm ²	I/A
ACS-CHK-B3	1.5	300x102x112	4.0	4	8.0
ACS-CHK-C3	0.8	300x102x112	4.0	4	14.0
SACL21	3.2	76x63x62	1.0	4	8.5
SACL22	1.5	92x76x63	1.3	10	15
SACL23	0.7	92x76x63	1.3	10	22
SACL24	0.7	92x76x63	1.9	6	28

Brake Options

The ACS 100 can be equipped with a brake unit. For more information please refer to page 45 for the ACS 100 brake options.

ACS 140 Machinery Drive

0.12 kW - 2.2 kW Supply Voltage 200 - 480 V

Unique features

- Fast and extensive I/O
- PID control
- Application macros
- Many installation possibilities
- 200 - 480 V, 1-phase or 3-phase

More value for money

- Possibility to have IP 21 enclosure
- Very fast and accurate control
- Extremely good repeatability
- Cost optimization without the panel

Mounting options

In addition to the conventional wall mounting and time-saving DIN rail mounting, ACS 140 also offers flange-mounting. The heatsink is located outside the enclosure and hence the major share of the power loss is external to the enclosure.

Heatsinkless series

In cases where space is a limitation, drives without a heatsink can be delivered as standard. The user has to provide an installation surface with sufficient cooling. For more information, please refer to the ACS 140 User's Manual.

Mounting options



heatsinkless



wall mounting



mounting on DIN rail



flange mounting

Dimensions



frame size H



frame size A

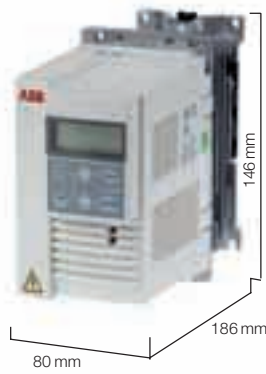

frame size B



frame size C



frame size D

ACS 140 Technical Specification

Mains connection

Power range: 0.12 - 2.2 kW

Voltage: 1-phase and 3-phase, 200 to 240 V, $\pm 10\%$
3-phase, 380 to 480 V, $\pm 10\%$

Frequency: 48 to 63 Hz

Power Factor: 0.98

Use 60°C rated power cable (75°C if T_{amb} above 45°C).

Max. wire sizes (mm²)

- 4 single core/torque 0.8 Nm

Motor connection

Voltage: 3-phase, from 0 to U_{SUPPLY}

Frequency: 0 to 300 Hz

Continuous loading capability (constant torque at a max. ambient temperature of 40°C): Rated output current I_2 .

Overload capacity (at a max. ambient temp. of 40°C):

- at constant torque $1.5 \times I_{2N}$, for 1 minute every 10 minutes
- at constant torque $1.25 \times I_{2N}$, for 2 minutes every 10 minutes

Characteristic data for short-time, intermittent and periodic load cycles are available on request.

Switching frequency:

Standard 4 kHz, Low-noise 8 kHz, Silent 16 kHz

Acceleration time: 0.1 to 1800 s

Deceleration time: 0.1 to 1800 s

For max. motor cable lengths see p. 24.

Programmable control connections

Max. wire sizes (mm²)

- 0.5-1.5 (AWG 22...AWG 16)/torque 0.4 Nm

Two analog inputs:

- Voltage signal: 0 (2) to 10 V, 200 k Ω single-ended
- Current signal: 0 (4) to 20 mA, 500 Ω single-ended
- Potentiometer reference value:
10 V $\pm 2\%$ max. 10 mA, 1 k $\Omega \leq R \leq 10$ k Ω
- Response time: ≤ 60 ms
- Resolution: 0.1%
- Accuracy: $\pm 1\%$

One analog output: 0 (4) to 20 mA, load $< 500 \Omega$

Auxiliary voltage: 12 V DC, max. 100 mA

Five digital inputs:

- 12 V... 24 V DC with internal or external supply, PNP and NPN
- Input impedance: 1.5 k Ω
- Response time: ≤ 9 ms

Two relay outputs:

- Switching voltage: 12 to 250 V AC or max 30 V DC/0.5 A
- Maximum continuous current: 10 mA to 2 A

Serial communication for the control panel or external control: Modbus protocol

Protection limits

Overvoltage, 200 to 240 V units

- Running V DC: 420 (corr. to 295 V input)
- Start inhibit V DC: 390 (corr. to 276 V input)

Overvoltage, 380 to 480 V units

- Running V DC: 842 (corr. to 595 V input)
- Start inhibit V DC: 661 (corr. to 380 - 415 V input)
765 (corr. to 440 - 480 V input)

Undervoltage, 200 to 240 V units

- Running V DC: 200 (corr. to 142 V input)
- Start inhibit V DC: 230 (corr. to 162 V input)

Undervoltage, 380 to 480 V units

- Running V DC: 333 (corr. to 247 V input)
- Start inhibit V DC: 436 (corr. to 380 - 415 V input)
505 (corr. to 440 - 480 V input)

Environmental limits

Ambient temperatures:

- Output current = I_2 , $f_{switch} = 4$ kHz: 0 to 40°C
- Output current = $0.8 \cdot I_2$, $f_{switch} = 4$ kHz: 40 to 50°C
- Output current = I_2 , $f_{switch} = 8$ kHz: 0 to 30°C
- Output current = $0.9 \cdot I_2$, $f_{switch} = 8$ kHz: 30 to 40°C
- Output current = $0.75 \cdot I_2$, $f_{switch} = 16$ kHz: 0 to 30°C¹⁾

Altitude:

- Output current = I_2 : 0 to 1000 m
- Output current reduced by 1% per 100 m over 1000 m to 2000 m

Relative humidity: lower than 95% (without condensation)

Protection class: IP 20

Paint colour: NCS 1502-Y, RAL 9002, PMS 420 C

Contamination levels: no conductive dust, corrosive liquids or gases (IEC 721-3-3).

Product compliance

- Low Voltage Directive 73/23/EEC with supplements
- EMC Directive 89/336/EEC with supplements
- Quality assurance system ISO 9001 and ISO 14001
- CE, UL, ULc and C-Tick approvals

Options

- Control panel
- RS 485/232 adapter
- DriveWindow Light 2
- Extension cable 3 m with IP 65 Kit for control panels PEC-98-0008
- EMC IP 20 input filters
- Braking units and choppers
- Input and output chokes
- NEMA 1/ IP 21 Installation kits
- Fieldbus modules

¹⁾ Except ACS 143-1K1-3 and ACS 143-2K1-3 where output current = $0.55 \times I_2$, $f_{SWITCH} = 16$ kHz: 0 to 30°C.

ACS 140 Technical Data

0.12 kW - 2.2 kW Supply Voltage 200 - 240 V± 10%

1-phase supply with heatsink

Type code	Nominal motor P_N ²⁾ kW	Nominal ratings			Max. output current A	Over-current (peak) A	Over-temp. (heat sink) °C	Line fuse ¹⁾ A	Power losses	
		Frame size/weight kg	Input current I_{1N} A	Output current I_{2N} A					Power circuit W	Control circuit W
ACS 141-K18-1	0.12	A/0.9	2.7	1.0	1.5	3.2	90	6	7	8
ACS 141-K25-1	0.18	A/0.9	4.4	1.4	2.1	4.5	90	6	10	10
ACS 141-K37-1	0.25	A/0.9	5.4	1.7	2.6	5.5	90	10	12	12
ACS 141-K75-1	0.37	A/0.9	6.9	2.2	3.3	7.1	90	10	13	14
ACS 141-1K1-1	0.55	A/0.9	9.0	3.0	4.5	9.7	90	10	19	16
ACS 141-1K6-1	0.75	B/1.2	10.8	4.3	6.5	13.8	90	16	27	17
ACS 141-2K1-1	1.1	C/1.6	14.8	5.9	8.9	19.0	95	16	39	18
ACS 141-2K7-1	1.5	C/1.6	18.2	7.0	10.5	23.5	95	20	48	19
ACS 141-4K1-1	2.2	D/1.9	22.0	9.0	13.5	34.5	95	25	70	20

1-phase supply heatsinkless

Type code	Nominal motor P_N ²⁾ kW	Nominal ratings			Max. output current A	Over-current (peak) A	Over-temp. (heat sink) °C	Line fuse ¹⁾ A	Power losses	
		Frame size/weight kg	Input current I_{1N} A	Output current I_{2N} A					Power circuit W	Control circuit W
ACS 141-H18-1	0.12	H/0.8	2.7	1.0	1.5	3.2	90	6	7	8
ACS 141-H25-1	0.18	H/0.8	4.4	1.4	2.1	4.5	90	6	10	10
ACS 141-H37-1	0.25	H/0.8	5.4	1.7	2.6	5.5	90	10	12	12
ACS 141-H75-1	0.37	H/0.8	6.9	2.2	3.3	7.1	90	10	13	14
ACS 141-1H1-1	0.55	H/0.8	9.0	3.0	4.5	9.7	90	10	19	16
ACS 141-1H6-1	0.75	H/0.8	10.8	4.3	6.5	13.8	90	16	27	17

3-phase supply with heatsink

Type code	Nominal motor P_N ²⁾ kW	Nominal ratings			Max. output current A	Over-current (peak) A	Over-temp. (heat sink) °C	Line fuse ¹⁾ A	Power losses	
		Frame size/weight kg	Input current I_{1N} A	Output current I_{2N} A					Power circuit W	Control circuit W
ACS 143-K75-1	0.37	A/0.8	3.2	2.2	3.3	7.1	90	6	13	14
ACS 143-1K1-1	0.55	A/0.8	4.2	3.0	4.5	9.7	90	6	19	16
ACS 143-1K6-1	0.75	B/1.1	5.3	4.3	6.5	13.8	90	6	27	17
ACS 143-2K1-1	1.1	C/1.5	7.2	5.9	8.9	19.0	90	10	39	18
ACS 143-2K7-1	1.5	C/1.5	8.9	7.0	10.5	23.5	95	10	48	19
ACS 143-4K1-1	2.2	D/1.8	12.0	9.0	13.5	34.5	95	16	70	20

¹⁾ Fuse type: UL class CC or T. For non-UL installations IEC269 gG.

²⁾ P_N rated motor power. The power ratings in kW apply to most 2- and 4-pole IEC 34 motors. The current ratings are the same regardless of supply voltages. The rated current of the ACS 140 drive must be higher than or equal to the rated motor current to achieve the rated motor power given in the table.

ACS 140 Technical Data

0.37 kW - 2.2 kW Supply Voltage 380 - 480 V ± 10%

3-phase supply with heatsink

Type code	Nominal motor P_N ²⁾ kW	Nominal ratings			Max. output current A	Over- current (peak) A	Over- temp. (heat sink) °C	Line fuse ¹⁾ A	Power losses	
		Frame size/ weight kg	Input current I_{1N} A	Output current I_{2N} A					Power circuit W	Control circuit W
ACS 143-K75-3	0.37	A/0.8	2.0	1.2	1.8	4.2	90	6	14	14
ACS 143-1K1-3	0.55	A/0.8	2.8	1.7	2.6	5.6	90	6	20	16
ACS 143-1K6-3	0.75	B/1.1	3.6	2.0	3.0	6.6	90	6	27	17
ACS 143-2K1-3	1.1	C/1.1	4.8	2.8	4.2	9.2	90	6	39	18
ACS 143-2K7-3	1.5	C/1.5	5.8	3.6	5.4	11.9	95	10	48	19
ACS 143-4K1-3	2.2	D/1.8	7.9	4.9	7.4	16.3	95	10	70	20

3-phase supply heatsinkless

Type code	Nominal motor P_N ²⁾ kW	Nominal ratings			Max. output current A	Over- current (peak) A	Over- temp. (heat sink) °C	Line fuse ¹⁾ A	Power losses	
		Frame size/ weight kg	Input current I_{1N} A	Output current I_{2N} A					Power circuit W	Control circuit W
ACS 143-H75-3	0.37	H/0.8	2.0	1.2	1.8	4.2	90	6	14	14
ACS 143-1H1-3	0.55	H/0.8	2.8	1.7	2.6	5.6	90	6	20	16
ACS 143-1H6-3	0.75	H/0.8	3.6	2.0	3.0	6.6	90	6	27	17
ACS 143-2H1-3	1.1	H/0.8	4.8	2.8	4.2	9.2	90	6	39	18

¹⁾ Fuse type: UL class CC or T. For non-UL installations IEC269 gG.

²⁾ P_N rated motor power. The power ratings in kW apply to most 2- and 4-pole IEC 34 motors. The current ratings are the same regardless of supply voltages. The rated current of the ACS 140 drive must be higher than or equal to the rated motor current to achieve the rated motor power given in the table.

ACS 140 Connection Examples

These connections are shown as an example only.
Please refer to the ACS 140 User's Manual for more detailed information.

DI configuration default (0)

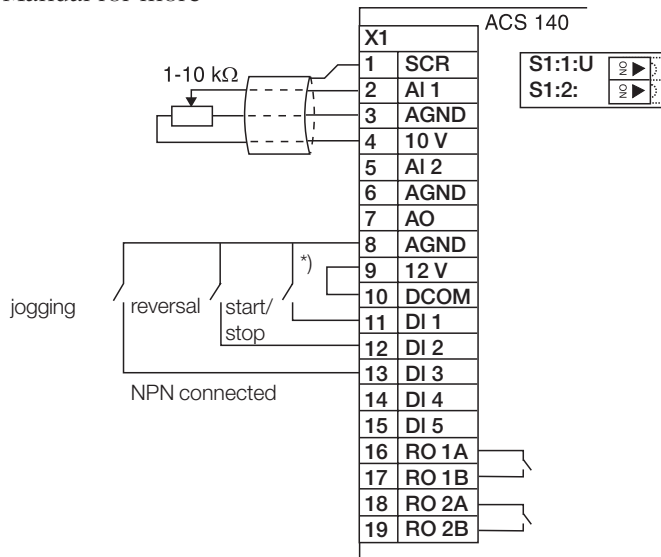

DI configuration default (1)

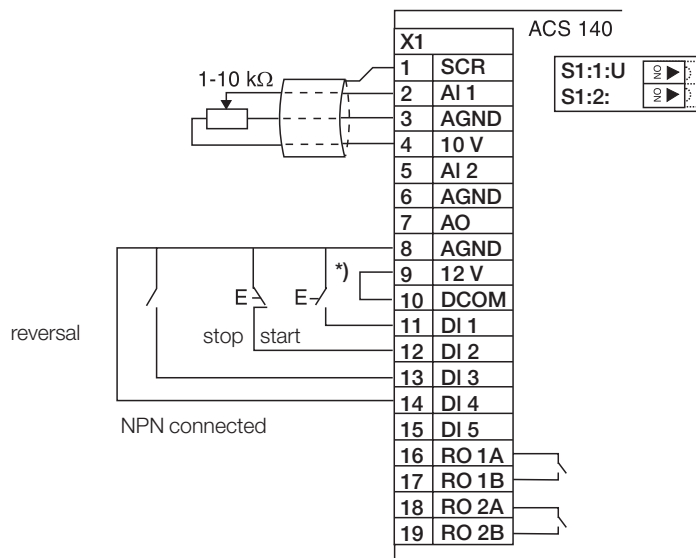

Frequency reference value from an external current source

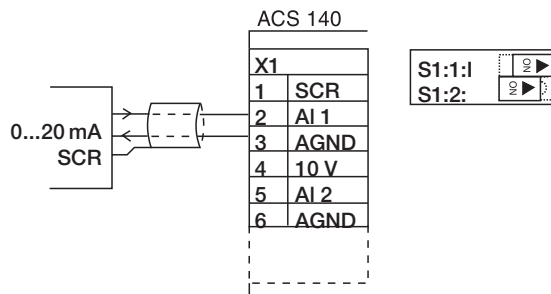

*) If external voltages are used open the jumper X1: 9,10.
Use the DCOM and digital inputs.

ACS 140 Options



Control panel

Type code: ACS 100 - PAN
ACS 140 drives can be bought with or without a detachable control panel. If you prefer to buy the drive without the control panel we still offer you a chance to have the panel as an option. Using the control panel, parameters can be exchanged between two ACS 140 drives. This is called parameter upload/download procedure.

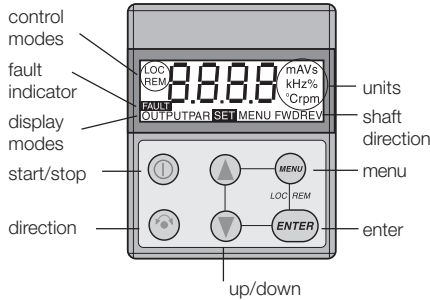

Panel Extension Cable Kit

Type code: PEC-98-0008
This option includes a gasket, a 3 m connection cable for control panels, fixing material for the cables and a drilling jig. With this kit IP 65 protection class is achieved.

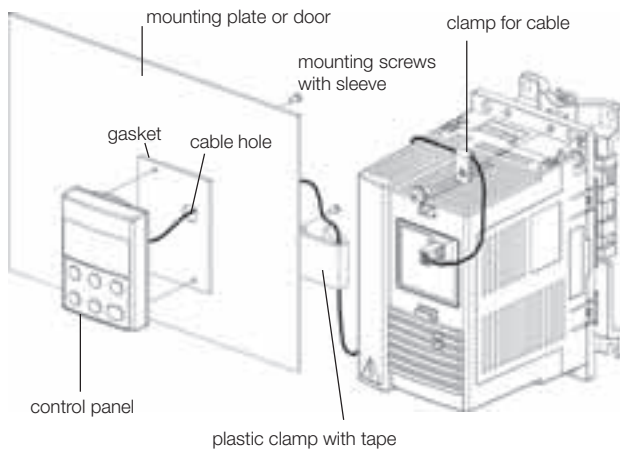

RS 485/232 Adapter

Type code: ACS 140 RS 485/232
If you want to control the ACS 140 drive via Modbus or use the DriveWindow Light 2 software you need to replace the panel with the RS 485/232 adapter. When the adapter is used, several ACS 140 units can be controlled using Modbus protocol. The modbus communication also creates the base for controlling the drive via other gateways.

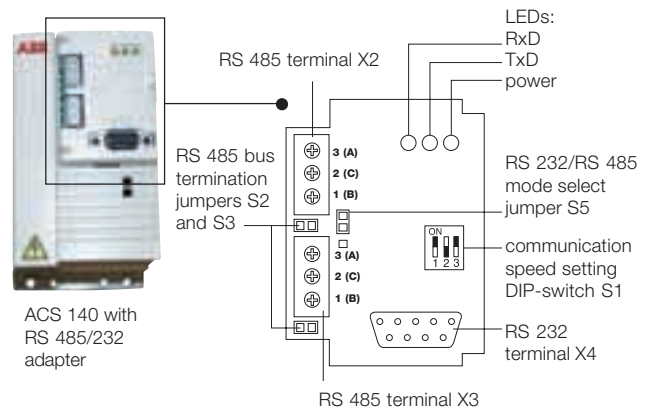

ABC fieldbus modules

Type codes: ABC-PDP and ABC-DEV
Up to ten drives can be controlled with one ABC fieldbus module. The drives may be of type ACS 140, ACS 160 and/or ACS 400. ABC modules are available for Profibus (type code ABC-PDP) and DeviceNet (type code ABC-DEV) fieldbus protocols. The module is DIN rail mountable with protection class IP 20. The ABC module requires 24 V DC power supply and provides an RS 485 Modbus interface for communication with the drives. The response time on the Modbus network is approximately 200 ms per drive.

ACS 140 Options

EMC Filters

Instructions to comply with EN61800-3:

To comply with:

- **1st Environment, unrestricted** distribution, please contact your ABB distributor.
- **1st Environment, restricted** distribution, always use optional RFI filter as specified in the table below.

To comply with:

- **2nd Environment, unrestricted** distribution, always use optional RFI filter as specified in the table below.
- **2nd Environment, restricted** distribution, always use optional RFI filter as specified in the table below. If RFI filters are to be avoided, an EMC plan has to be created between the customer and the sales person.

1-phase supply voltage 200 - 240 V, 0.12 - 2.2 kW

Type code	Filter type	Max. motor cable length m						Dimensions			
		Switching frequency						A	B	C	D
		1 st environment			2 nd environment						
4 kHz	8 kHz	16 kHz	4 kHz	8 kHz	16 kHz	mm	mm	mm	mm		
ACS 141-K18-1, -H18-1	ACS 100/140-IFAB-1	30	20	10	50	50	10	81	186	191	42
ACS 141-K25-1, -H25-1	ACS 100/140-IFAB-1	30	20	10	50	50	10	81	186	191	42
ACS 141-K37-1, -H37-1	ACS 100/140-IFAB-1	30	20	10	50	50	10	81	186	191	42
ACS 141-K75-1, -H75-1	ACS 100/140-IFAB-1	30	20	10	75	75	10	81	186	191	42
ACS 141-1K1-1, -1H1-1	ACS 100/140-IFAB-1	30	20	10	75	75	10	81	186	191	42
ACS 141-1K6-1, -1H6-1	ACS 100/140-IFAB-1	30	20	10	75	75	10	81	186	228	42
ACS 141-2K1-1	ACS 100/140-IFCD-1	30	20	10	75	75	10	81	286	211	42
ACS 141-2K7-1	ACS 100/140-IFCD-1	30	20	10	75	75	10	81	286	211	42
ACS 141-4K1-1	ACS 100/140-IFCD-1	30	20	10	75	75	10	81	286	218	42

3-phase supply voltage 380 - 480 V, 0.37 - 2.2 kW

Type code	Filter type	Max. motor cable length m						Dimensions			
		Switching frequency						A	B	C	D
		1 st environment			2 nd environment						
4 kHz	8 kHz	16 kHz	4 kHz	8 kHz	16 kHz	mm	mm	mm	mm		
ACS 143-K75-3, -H75-3	ACS 140-IFAB-3	30	20	10	30	30	10	81	186	191	42
ACS 143-1K1-3, -1H1-3	ACS 140-IFAB-3	30	20	10	50	50	10	81	186	191	42
ACS 143-1K6-3, -1H6-3	ACS 140-IFAB-3	30	20	10	50	50	10	81	186	228	42
ACS 143-2K1-3, -2H1-3	ACS 140-IFAB-3	30	20	10	50	50	10	81	286	211	42
ACS 143-2K7-3	ACS 140-IFCD-3	30	20	10	50	50	10	81	286	211	42
ACS 143-4K1-3	ACS 140-IFCD-3	30	20	10	50	50	10	81	286	218	42

RFI filter type code ACS 100 -FLT-C allows you to use longer motor cables. Please contact your ABB distributor. IFAB, IFCD and FLT-C filters with protection class IP 20.

Note! With types ACS...H mount the filter next to the drive.

3-phase supply voltage 200 - 240 V, 0.37 - 2.2 kW

Use EMC filter type ACS140-FLT-C with all ACS143-xKx-1 converter types. Maximum motor cable length is 100 m in 1st Environment, restricted distribution, with 4 kHz and 8 kHz switching frequency. For ACS143-4K1-1 with EMC filter the maximum continuous load is 70% of nominal.

NEMA 1/ IP 21 Installation Kit

Type code: NEMA 1/ IP 21

With this installation kit NEMA 1/ IP 21 protection class is achieved for ACS 140 and for the EMC filter, if the filter is attached directly to the drive.

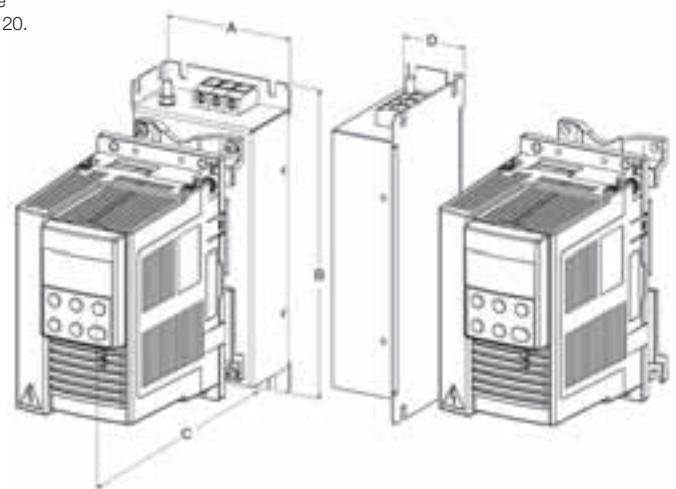

ACS 140 Options

Input and Output Chokes

Output chokes are used when motor cables above normal length are required. The cable can be roughly 1.5 times the standard cable length. This is possible because the output choke reduces capacitive currents and voltage reflections. The maximum switching frequency with output chokes is 4 kHz. Please note your local EMC regulations.

Optional input chokes can be used with the ACS 140 in case of a bad supply net. The chokes eliminate converter trips caused by overvoltage spikes. They also reduce line harmonics and therefore help to prevent other sensitive equipment in the same net from tripping.

efesotomasyon.com

Type code	Choke type		Max. motor cable length	
	Input choke	Output choke	with choke ¹⁾ m	without choke ¹⁾ m
1-phase Supply Voltage 200 - 240 V, 0.12 - 2.2 kW				
ACS 141-K18-1	SACL21	ACS-CHK-B3	75	50
ACS 141-K25-1	SACL21	ACS-CHK-B3	75	50
ACS 141-K37-1	SACL21	ACS-CHK-B3	75	50
ACS 141-K75-1	SACL21	ACS-CHK-B3	110	75
ACS 141-1K1-1	SACL21	ACS-CHK-B3	110	75
ACS 141-1K6-1	SACL22	ACS-CHK-B3	110	75
ACS 141-2K1-1	SACL22	ACS-CHK-C3	110	75
ACS 141-2K7-1	SACL23	ACS-CHK-C3	110	75
ACS 141-4K1-1	SACL24	ACS-CHK-C3	110	75
3-phase Supply Voltage 200 - 240 V, 0.37 - 2.2 kW				
ACS 143-K75-1	ACS-CHK-B3	ACS-CHK-B3	110	75
ACS 143-1K1-1	ACS-CHK-B3	ACS-CHK-B3	110	75
ACS 143-1K6-1	ACS-CHK-B3	ACS-CHK-B3	110	75
ACS 143-2K1-1	ACS-CHK-B3	ACS-CHK-C3	110	75
ACS 143-2K7-1	ACS-CHK-C3	ACS-CHK-C3	110	75
ACS 143-4K1-1	ACS-CHK-C3	ACS-CHK-C3	110	75
1-phase Supply Voltage 200 - 240 V, 0.12 - 0.75 kW / Heatsinkless				
ACS 141-H18-1	SACL21	ACS-CHK-B3	75	50
ACS 141-H25-1	SACL21	ACS-CHK-B3	75	50
ACS 141-H37-1	SACL21	ACS-CHK-B3	75	50
ACS 141-H75-1	SACL21	ACS-CHK-B3	110	75
ACS 141-1H1-1	SACL21	ACS-CHK-C3	110	75
ACS 141-1H6-1	SACL21	ACS-CHK-C3	110	75
3-phase Supply Voltage 380 - 480 V, 0.37 - 2.2 kW				
ACS 143-K75-3	ACS-CHK-A3	ACS-CHK-B3	45	30
ACS 143-1K1-3	ACS-CHK-A3	ACS-CHK-B3	75	50
ACS 143-1K6-3	ACS-CHK-A3	ACS-CHK-B3	110 ²⁾	75
ACS 143-2K1-3	ACS-CHK-B3	ACS-CHK-B3	110 ²⁾	75
ACS 143-2K7-3	ACS-CHK-B3	ACS-CHK-C3	110 ²⁾	75
ACS 143-4K1-3	ACS-CHK-C3	ACS-CHK-C3	110 ²⁾	75
3-phase Supply Voltage 380 - 480 V, 0.37 - 2.2 kW / Heatsinkless				
ACS 143-H75-3	ACS-CHK-A3	ACS-CHK-B3	45	30
ACS 143-1H1-3	ACS-CHK-A3	ACS-CHK-B3	75	50
ACS 143-1H6-3	ACS-CHK-A3	ACS-CHK-B3	110 ²⁾	75
ACS 143-2H1-3	ACS-CHK-A3	ACS-CHK-B3	110 ²⁾	75

¹⁾ Without EMC filter

²⁾ If the supply voltage is higher or equal to 440 V the maximum cable length is 100 m.

Technical data

Choke type	L/mH	Dimensions H x W x D mm	Weight kg	Max. cable mm ²	I/A
ACS-CHK-A3	4.0	300x102x112	3.2	4	4.0
ACS-CHK-B3	1.5	300x102x112	4.0	4	8.0
ACS-CHK-C3	0.8	300x102x112	4.0	4	14.0
SACL21	3.2	76x63x62	1.0	4	8.5
SACL22	1.5	92x76x63	1.3	10	15
SACL23	0.7	92x76x63	1.3	10	22
SACL24	0.7	92x76x63	1.9	6	28

Brake options

The ACS 140 can be equipped with a brake unit. For more information please refer to page 45 for the ACS 140 brake options.

ACS 160 Integral Drive

0.55 kW - 2.2 kW Supply Voltage 380 - 480 V

Unique features

- Hard and tight aluminium IP 65 enclosure
- Can be installed in any position on the wall or on the motor
- When on the motor, no room or cabinet space is required
- Unit has built-in EMC filter and brake chopper
- Simple positioning tasks with Positioning application macro

More value for money

- Robust and vibration tested tight IP 65 enclosure with varnished electronic boards
- With the fieldbus options, can be part of every major industrial and domestic control system
- Squared torque current ratings and PID control macro for HVAC systems and applications
- In addition to ABB motors, compatibility with other manufacturers' motors

Motor mounting

An excellent choice when a compact integrated drive is needed. Using an ACS 160 it is easy to convert a fixed speed motor to regulated operation.

Select the converter and motor mounting kit from the tables on page 30. To select an integrated drive and motor combination see pages 31-34.

Wall mounting

A robust IP 65 drive in ABB's low voltage range of frequency converters. The control panel is included as standard.

Dimensions of motor mounting unit

Type code	Frame size	A mm	B mm	C mm	D mm	E mm	Weight kg
ACS 163-1K1-3-A...2K7-3-A	R1	99	112	157	221	171	3.9
ACS 163-4K1-3-A	R2	99	112	157	261	171	4.6
ACS 163-1K1-3-B...2K7-3-B	R1	135	149	157	221	171	5.5
ACS 163-4K1-3-B	R2	135	149	157	261	171	6.3

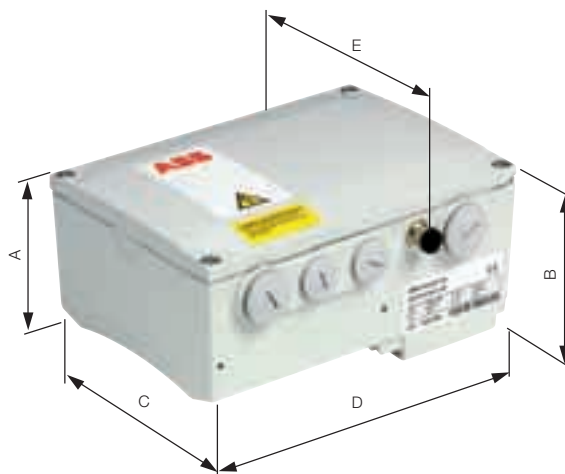

Dimensions of wall mounting unit

Type code	Frame size	A mm	B mm	C mm	Weight kg
ACS 163-1K1-3-D...2K7-3-D	R1	317	134	171	5.1
ACS 163-4K1-3-D	R2	357	134	171	5.8
ACS 163-1K1-3-E...2K7-3-E	R1	317	171	171	6.7
ACS 163-4K1-3-E	R2	357	171	171	7.5



ACS 160 Technical Specification

Mains connection

Power range: 0.55 - 2.2 kW

Voltage: 3-phase, 380 to 480 V $\pm 10\%$ ¹⁾

Frequency: 48 to 63 Hz

Power factor: 0.98

Motor connection

Voltage: 3-phase, from 0 to U_{supply}

Frequency: 0 to 250 Hz

Continuous loading capability (constant torque at maximum ambient temperature of 40°C):

- Rated output current I_{2N}

Overload capacity (at a max. ambient temperature of 40°C):

- At constant torque: $1.5 \cdot I_{2N}$ for one minute every 10 minutes
- Starting torque: $1.8 \cdot I_{2N}$ for two seconds
- Characteristic data for short time, intermittent and periodic load cycles are available on request.

Switching frequency:

- Standard 4 kHz
- Low noise 8 kHz²⁾

Acceleration time: 0.1 to 1800 s

Deceleration time: 0.1 to 1800 s

Programmable control connections

Two analog inputs:

- Voltage signal: 0 (2) to 10 V, 200 k Ω single ended
- Current signal: 0 (4) to 20 mA, 500 Ω single ended
- Potentiometer reference: 10 V $\pm 2\%$ max. 10 mA, 1 k $\Omega \leq R \leq 10$ k Ω
- Response time: < 64 ms
- Resolution: 0.1%
- Accuracy: $\pm 1\%$

One analogue output: 0 (4) to 20 mA, load < 500 Ω

Auxiliary voltage: 24 V DC, max 180 mA

Five digital inputs: 12-24 V DC with internal or external supply, PNP and NPN logic

- Input impedance: 1.5 k Ω
- Response time: < 5 ms

Two relay outputs:

- Switching voltage: 12 to 250 V AC or max. 30 V DC / 0.5 A
- Max. continuous current: 10 mA to 2 A

Built-in brake chopper

Pulse encoder: Connected to digital inputs DI4 and DI5, max. 25 V DC / 100 mA, max. pulse frequency 200 kHz

Serial communication for external control:

- Modbus protocol as standard, other fieldbus options available: PROFIBUS-DP, InterBus-S, DeviceNet, CANOpen, LONWORKS[®]

Programmable features²⁾

Nine application macros for easy configuration:

- Factory, ABB Standard, 3-Wire, Alternate, Motor Potentiometer, Hand-Auto, PID-Control, Pre-magnetize, Positioning

Skip frequencies: Two bands

Start and stop: Flying start, Torque boosting, Premagnetising function, DC hold function, DC injection braking

Functions:

- Output current and frequency limit, Programmable volts/herz ratio, IR compensation, Slip compensation, PID-control with sleep function, Seven preset speeds, Automatic fault reset, Two acceleration and two deceleration ramps, Control for electromechanical brake

Protection

Limits

- Overcurrent trip limit: $3.5 \cdot I_{2N}$
- DC current regulation limit: $0.5 \dots 1.5 \cdot I_{2N}$
- DC overvoltage trip limit: 875 V
- DC undervoltage trip limit: 333 V
- Power-loss ride-through: 500 ms
- Overtemperature limit: 105°C inside power module

Inverter protection:

- Output short circuit, Input phase loss, Inverter overload, Output earth-fault, Serial communication error, Loss of AI signal, I/O terminal short circuit, Auxiliary voltage short circuit, Brake resistor overload

Motor protection:

- Stall protection, Overtemperature protection by P_t estimation; In motor mounting version also by PTC

Environmental limits

Ambient operating temperature³⁾:

- Output current = I_2 and $f_{\text{switch}} = 4$ kHz: -10 to 40°C
- Output current = $0.6 \cdot I_2$ and $f_{\text{switch}} = 4$ kHz: 40 to 50°C
- Output current = $0.7 \cdot I_2$ and $f_{\text{switch}} = 8$ kHz: -10 to 40°C
- Refer to page 31 for more derating information

Installation altitude:

- Output current = I_2 : 0 to 1000 m
- Output current reduced by 1% for every 100 m above 1000 m. Max altitude 2000 m.

Protection class: IP 65

Colour: NCS 1502-Y, RAL 9002, PMS 420 C

Contamination levels: According to IEC 721-3-3

Electromagnetic Compatibility (EMC):

- Units with built-in filter: Fulfils EN61800-3 1st and 2nd Environment distribution limits
- Standard units: Fulfils EN61800-3 2nd Environment restricted distribution limits
- Units without filter: For floating networks and to EN61800-3 2nd Environment with EMC plan.

Harmonic emissions:

- Units with < 1 kW input power fulfil EN61000-3-2
- Units with > 1 kW input power are to be used only in professional applications

Product compliance

- Low Voltage Directive 73/23/EEC with amendments
- EMC Directive 89/336/EEC with amendments
- Quality Assurance systems ISO 9001 and ISO 14001
- CE, UL, cUL and C-Tick approvals

¹⁾ For ACS163-xKx-3-D units 380 to 500 V $\pm 10\%$

²⁾ Adjustable only with control panel.

³⁾ Minimum ambient temperature for wall mounting version 0°C.

ACS 160 Technical Data

0.55 kW - 2.2 kW Supply Voltage 380 - 480 V ± 10%

Type code	Nominal ratings										Power losses	
	Nominal motor P _N ⁶⁾	Frame size/ weight	3~ supply voltage ± 10%	Input current I _{IN}	Cont. output current I _{2N} ¹⁾	Max. current 150% I _{max} ²⁾	Max. starting current 180% ³⁾	Cont. output current I _{2NSQ} ^{1) 4) 6)}	Over-current limit (peak)	Line fuse ⁵⁾	Power circuit W	Control circuit W
	kW	kg	V	A	A	A	A	A	A			
Motor mounting version, standard												
ACS 163-1K1-3-A	0.55	R1 / 3.9	380-480	1.6	1.8	2.7	3.2	2.2	7.1	4	17	16
ACS 163-1K6-3-A	0.75	R1 / 3.9	380-480	2.2	2.4	3.6	4.3	2.8	9.5	4	23	17
ACS 163-2K1-3-A	1.1	R1 / 3.9	380-480	3.2	3.4	5.1	6.1	3.8	13	6	33	18
ACS 163-2K7-3-A	1.5	R1 / 3.9	380-480	4.1	4.1	6.2	7.4	5.0	16	10	45	19
ACS 163-4K1-3-A	2.2	R2 / 4.6	380-480	6.0	5.4	8.1	9.7	6.6	21	10	66	20
Motor mounting version, with built-in filter												
ACS 163-1K1-3-B	0.55	R1 / 5.5	380-480	1.6	1.8	2.7	3.2	2.2	7.1	4	17	18
ACS 163-1K6-3-B	0.75	R1 / 5.5	380-480	2.2	2.4	3.6	4.3	2.8	9.5	4	23	19
ACS 163-2K1-3-B	1.1	R1 / 5.5	380-480	3.2	3.4	5.1	6.1	3.8	13	6	33	20
ACS 163-2K7-3-B	1.5	R1 / 5.5	380-480	4.1	4.1	6.2	7.4	5.0	16	10	45	21
ACS 163-4K1-3-B	2.2	R2 / 6.3	380-480	6.0	5.4	8.1	9.7	6.6	21	10	66	22
Wall mounting version, filterless												
ACS 163-1K1-3-D	0.55	R1 / 5.1	380-500	1.6	1.8	2.7	3.2	2.2	7.1	4	17	16
ACS 163-1K6-3-D	0.75	R1 / 5.1	380-500	2.2	2.4	3.6	4.3	2.8	9.5	4	23	17
ACS 163-2K1-3-D	1.1	R1 / 5.1	380-500	3.2	3.4	5.1	6.1	3.8	13	6	33	18
ACS 163-2K7-3-D	1.5	R1 / 5.1	380-500	4.1	4.1	6.2	7.4	5.0	16	10	45	19
ACS 163-4K1-3-D	2.2	R2 / 5.8	380-500	6.0	5.4	8.1	9.7	6.6	21	10	66	20
Wall mounting version, with built-in filter												
ACS 163-1K1-3-E	0.55	R1 / 6.7	380-480	1.6	1.8	2.7	3.2	2.2	7.1	4	17	18
ACS 163-1K6-3-E	0.75	R1 / 6.7	380-480	2.2	2.4	3.6	4.3	2.8	9.5	4	23	19
ACS 163-2K1-3-E	1.1	R1 / 6.7	380-480	3.2	3.4	5.1	6.1	3.8	13	6	33	20
ACS 163-2K7-3-E	1.5	R1 / 6.7	380-480	4.1	4.1	6.2	7.4	5.0	16	10	45	21
ACS 163-4K1-3-E	2.2	R2 / 7.5	380-480	6.0	5.4	8.1	9.7	6.6	21	10	66	22

1) Power stages are designed for continuous I_{2N}/I_{2NSQ} current. These values apply at altitudes of less than 1000 m ASL. Current limits for squared torque are not valid if the ACS 160 drive is used on top of a non ABB motor.
 2) 150% of nominal current I_{2N} allowed for one minute every 10 minutes.

3) 180% of nominal current I_{2N} allowed for two seconds.
 4) No overloadability. Derate to 90% when using 8 kHz switching frequency. Rating is not valid if the ACS 160 is installed on top of a non ABB motor.
 5) Fuse type: UL class CC or T. For non-UL installations IEC269gG.

6) In squared torque applications use the values in column Cont. output current I_{2NSQ} to select the nominal motor power.
 Use 60°C rated power cable (75°C if T_{amb} above 45°C).
 Follow local rules for cable cross-sections. Shielded motor cable is recommended.
 Max. wire sizes/Power terminals (mm²)
 - single core: 4 (AWG 12), stranded: 2.5 (AWG 14)/torque 0.8 Nm
 Max. wire sizes/Control terminals (mm²)
 - 0.5-1.5 (AWG 22...AWG 16)/torque 0.4 Nm

ACS 160 Connection Examples

These connections are shown as examples only. Please refer to the ACS 160 User's Manual for more detailed information.

Analog inputs

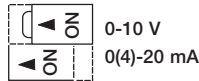

ACS 160 X1

Analog inputs

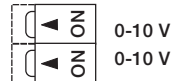

ACS 160 X1

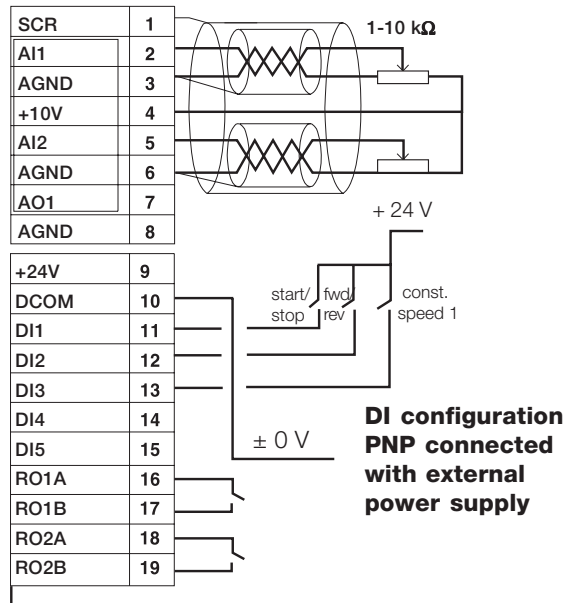
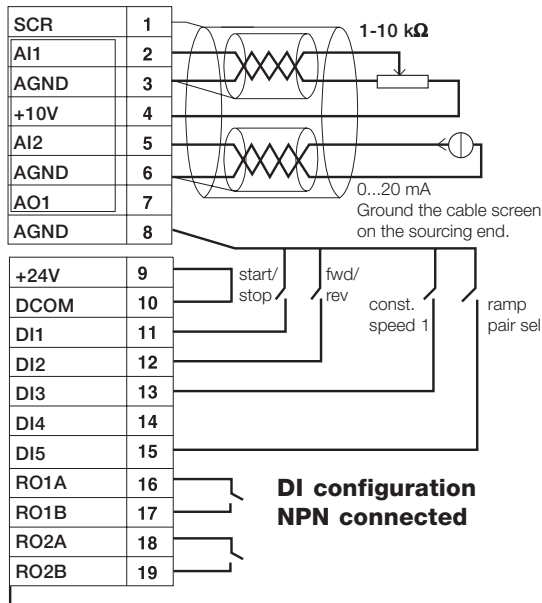

ACS 160 Electro Magnetic Compatibility

For floating networks or when EN61800-3 EMC standard is not required

In floating networks if the EN61800-3 EMC requirements do not need be fulfilled, the 163-xKx-3-D units can be used. The maximum motor cable length depends on the drive's input voltage and switching frequency.

With ACS163-xKx-3-D one can use output chokes to increase maximum motor cable length or input chokes to reduce problems caused by net voltage variation. Please refer to page 24 for more technical data about the chokes.

To fulfil EN61800-3 EMC requirements

If the EN61800-3 2nd Environment EMC requirements need to be fulfilled, the 163-xKx-3-A and 163-xKx-3-E units can be used.

If the EN61800-3 1st Environment EMC requirements need to be fulfilled, the 163-xKx-3-B and 163-xKx-3-E units can be used.

Motor cable lengths (m) to ensure accurate drive functionality

Wall mounting without EMC Filter Type code	Input voltage Switching frequency			
	400 V		500 V	
	4 kHz	8 kHz	4 kHz	8 kHz
ACS163-1K1-3-D	40	20	20	10
ACS163-1K6-3-D	60	20	20	10
ACS163-2K1-3-D	80	20	20	10
ACS163-2K7-3-D	90	50	40	30
ACS163-4K1-3-D	100	100	80	80

Selection table

Type code	Input choke	Output choke ¹⁾	Max. motor cable length m
ACS 163-1K1-3-D	ACS-CHK-A3	ACS-CHK-B3	60
ACS 163-1K6-3-D	ACS-CHK-A3	ACS-CHK-B3	80
ACS 163-2K1-3-D	ACS-CHK-B3	ACS-CHK-B3	100
ACS 163-2K7-3-D	ACS-CHK-B3	ACS-CHK-C3	120 ²⁾
ACS 163-4K1-3-D	ACS-CHK-C3	ACS-CHK-C3	140 ²⁾

¹⁾ Supply voltage 380 - 480 V, switching frequency 4 kHz.

²⁾ If the supply voltage is higher or equal to 440 V the maximum cable length is 100 m.

Motor cable lengths (m) to comply with EN61800-3 2nd Environment restricted distribution

Type code	Input voltage 380-480 V ± 10% Switching frequency	
	4 kHz	8 kHz
	ACS163-1K1-3-E	30
ACS163-1K6-3-E	30	20
ACS163-2K1-3-E	30	20
ACS163-2K7-3-E	30	20
ACS163-4K1-3-E	55	40

Motor cable lengths (m) to comply with EN61800-3 1st Environment

Type code	Input voltage 380-480 V ± 10% Switching frequency	
	4 kHz	8 kHz
	restricted/unrestricted distribution	restricted/unrestricted distribution
ACS163-1K1-3-E	10/5	10/5
ACS163-1K6-3-E	10/5	10/5
ACS163-2K1-3-E	10/5	10/5
ACS163-2K7-3-E	10/5	10/5
ACS163-4K1-3-E	10/5	10/5

ACS 160 Options

IP 65 Control Panel Kit

Type code: CA-PAN-L

ACS 160 drives can be bought with or without a detachable control panel. In motor mounted units the control panel is offered as an option and in wall mounted units it is included automatically. Using the control panel, parameters can be exchanged between two ACS 160 drives. This is called parameter upload/download procedure.



Fieldbus Gateways and RS 485/232 Adapter

Type code: see the table below

The ACS 160 can be connected to all major automation systems with the help of the large variety of fieldbuses. The fieldbus gateways are available in robust IP 65 boxes, which can be conveniently fitted on one side of the drive. The Modbus protocol is as standard in all ACS 160 units and can be used by means of an RS 485/232 adapter (CFB-RS).



Fieldbus technical data

Fieldbus	Type code	Protocol mode	Device profile	Baudrate (min.-max.)
PROFIBUS	CFB-PDP	DP	Profidrive V.2	9.6 kbit/s - 12 Mbit/s
InterBus-S	CFB-IBS	PCP	Drivecom (Profile 21)	500 kbit/s
DeviceNet	CFB-DEV	N.A.	AC Drive profile	125 - 500 kbit/s
CANOpen	CFB-CAN	N.A.	Drives and Motion control (DS402 V. 1.1)	10 - 1000 kbit/s
LONWORKS®	CFB-LON	LONTALK®	Variable Speed Motor Drive 6010	78 kbit/s
Modbus	CFB-RS	RTU	Profidrive	300 - 19200 bit/s

N.A. = Not applicable

ABC fieldbus modules

Type codes: ABC-PDP and ABC-DEV

Up to ten drives can be controlled with one ABC fieldbus module. The drives may be of type ACS 140, ACS 160 and/or ACS 400. ABC modules are available for Profibus (type code ABC-PDP) and DeviceNet (type code ABC-DEV) fieldbus protocols. The module is DIN rail mountable with protection class IP 20. The ABC module requires 24 V DC power supply and provides an RS 485 Modbus interface for communication with the drives. The response time on the Modbus network is appr. 200 ms per drive.

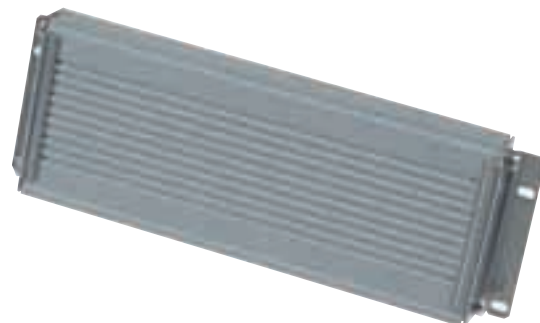

Integral Brake Resistors

Type code: see the table below

The ACS 160 offers an optimal solution for braking, because brake choppers are built-in as a standard feature in all ACS 160 drives. The IP 65 brake resistors can be fitted on one side of the ACS 160.

Brake resistor technical data

ACS 160 Type code	Type code	Resistance Ohm	Max. average resistor power W	Max. instantaneous resistor power W
ACS 163-1K1-3-X	CA-BRK-R1-1	390	39	700
ACS 163-1K6-3-X	CA-BRK-R1-1	390	39	950
ACS 163-2K1-3-X	CA-BRK-R1-2	125	39	1500
ACS 163-2K7-3-X	CA-BRK-R1-2	125	39	2100
ACS 163-4K1-3-X	CA-BRK-R2	125	45	3080

X stands for type code A, B, D or E

ACS 160 Options

Motor mounting kits

Type code: CMK-A-71 and CMK-A-80-100

Using a motor mounting kit, an ACS 160 drive can be retrofitted on an existing fixed speed motor to convert it into an integral variable speed unit. Motor mounting kits are available for ABB's M2AA, M3AA, M2VA, M3VRF/S and M3ARF/S motors. Please see pages 32-34.

The table below provides the information needed when selecting a motor mounting kit for ABB motors. Contact an ABB office or your local distributor about motor mounting kit availability for motors from other manufacturers.

Motor mounting kits

Motor type	Motor nominal output kW	Motor frame size			Type code
		3000 rpm 2-pole	1500 rpm 4-pole	1000 rpm 6-pole	
ABB	0.12	-	-	71	CMK-A-71
M3VA/AA	0.18	-	-	71A	
M2VA/AA	0.25	-	71A	71B	CMK-A-80-100
M3VRF/S	0.37	71A	71B	80A	
M3ARF/S	0.55	71B	80A	80B	
	0.75	80A	80B	90S	
	1.1	80B	90S	90L	
	1.5	90S	90L	100L	
	2.2	90L	100LA	-	

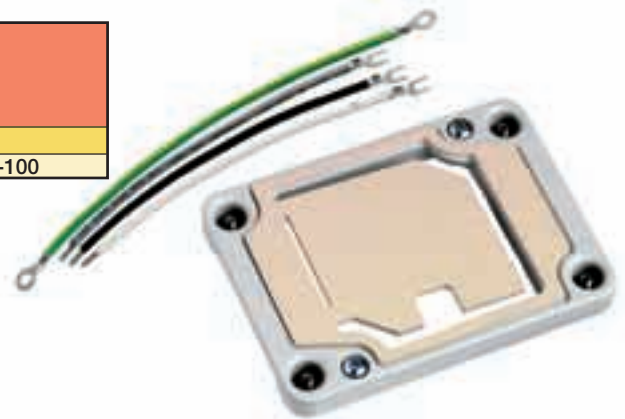

Cable gland set

Type code: CA-MGS

A selection of cable glands for ACS 160 drives. The glands are for the following cable diameters: 5-9 mm (2 pcs), 6-12 mm (2 pcs) and 9-16 mm (2 pcs).



ACS 160 Dimensions with fieldbus adapter and brake resistor attached

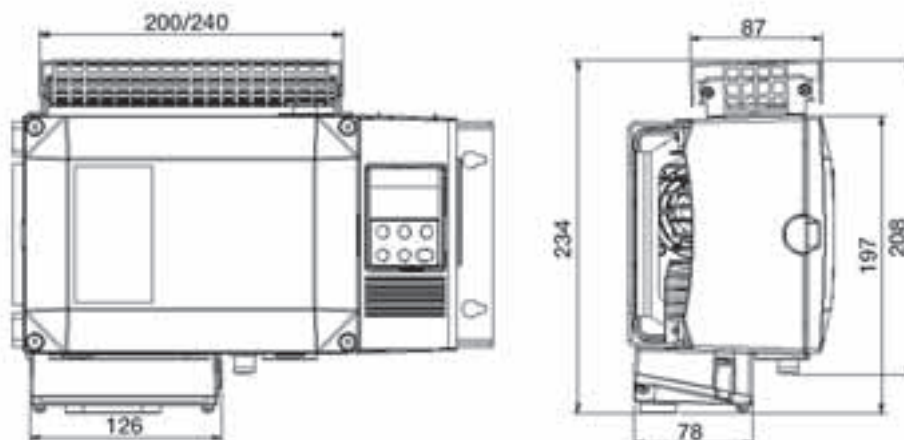

ACS 160 and Motor Combinations

ABB offers a comprehensive range of AC low voltage motors. Standard motors available from ABB's central stocks can be used with the ACS 160.

Our M3AA aluminium motors offer the highest efficiency levels, very long bearing lifetime and low temperature rise for cost-efficient and environmentally-friendly operation. See the M3000 Aluminium Motors catalogue for detailed information.

Our M2VA/AA aluminium motors are quality products in the EFF2 class for volume applications, providing an ideal efficiency level for many different needs. See the M2000 Aluminium Motors catalogue for detailed information.

The ACS 160 can also be fitted to ABB's M3VRF/S and M3ARF/S brake motor series. These induction motors have standard dimensions and outputs and are equipped with an electromagnetic disk brake. See the M3000 Brake Motors catalogue for detailed information.

ACS 160 and motor combinations are also available as ready assembled and parameterized M3VK Integral motors. See the M3000 Integral motors catalogue for detailed information.

For more information about ABB motors, please refer to our website <http://www.abb.com/motors&drives> and select category Low Voltage Motors/Library of Documents.

Derating information

Derating with output frequency / M3AA/M2AA motors

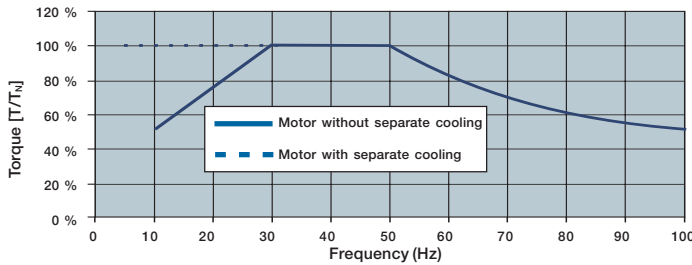

Derating with mains voltage

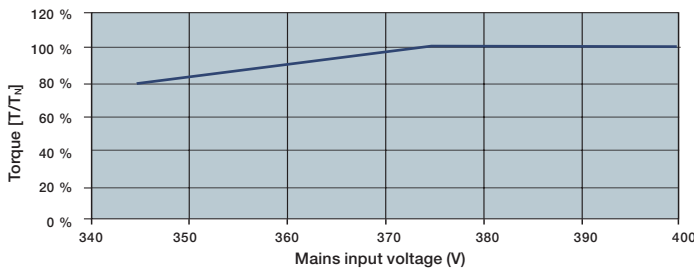

Derating with temperature

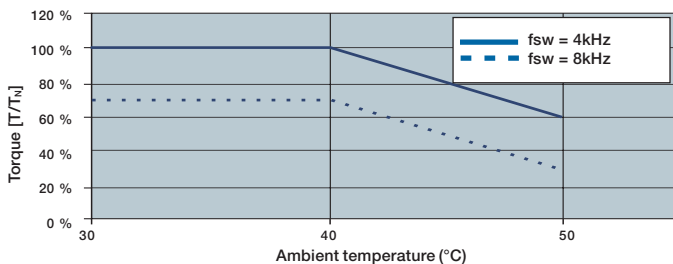

If the ACS 160 is used at low frequencies, separate cooling is recommended, especially when the motor load is high. Most ABB motors can be equipped with a separate cooling unit.

M3AA/M2AA



M3VA/M2VA



M3VRF/S and M3ARF/S



M2VA with separate cooling unit



M3VA/AA Motor Technical Data

The motors listed here are shown as examples only.
For the latest information on these and other motors,
please contact an ABB office or your local distributor.
Specifications subject to change without notice.



TEFC squirrel cage three-phase motors M3VA/AA IP 55 IC 411, insulation class F, temperature rise class B

Output kW	Type designation	Product code	Speed r/min	Efficiency		Power factor FL cos φ	Current		Torque			Moment of inertia J=1/4 GD ² kgm ²	Weight kg	Sound pressure level LP dB(A)	ACS 160 type code ^{1) 2)}	
				Full load 100%	3/4 load 75%		I _N A	I _S I _N	T _N Nm	T _S T _N	T _{max} T _N					
2-pole = 3000 r/min		400 V, 50 Hz		On request												
1.1	M3VA 80C															
1.5	M3AA 90L	3GAA 091 312-••C	2900	85.9	86.5	0.87	3.0	7.7	5.0	2.7	3.6	0.0024	16	60	ACS 163-2K7-3-A/-B	
2.2	M3AA 90LB	3GAA 091 313-••C	2880	85.8	87.1	0.87	4.4	7.4	7.3	3.0	3.6	0.0027	18	60	ACS 163-4K1-3-A/-B	
4-pole = 1500 r/min		400 V, 50 Hz		On request												
1.1	M3AA 90L	3GAA 092 312-••C	1420	83.9	84.3	0.80	2.4	6.1	7.4	2.9	3.4	0.0043	16	50	ACS 163-2K1-3-A/-B	
1.5	M3AA 100LA	3GAA 102 311-••C	1440	85.6	85.5	0.82	3.2	6.9	10.0	2.8	3.4	0.0069	21	54	ACS 163-2K7-3-A/-B	
2.2	M3AA 100LC	3GAA 102 313-••C	1450	86.8	86.5	0.77	4.8	8.5	14.5	4.0	4.6	0.009	25	54	ACS 163-4K1-3-A/-B	

¹⁾ -A = standard, -B = with built-in filter

²⁾ ACS 160 types are selected according to the Continuous output current I_{2N}, see page 27.

Dimensions with ACS 160

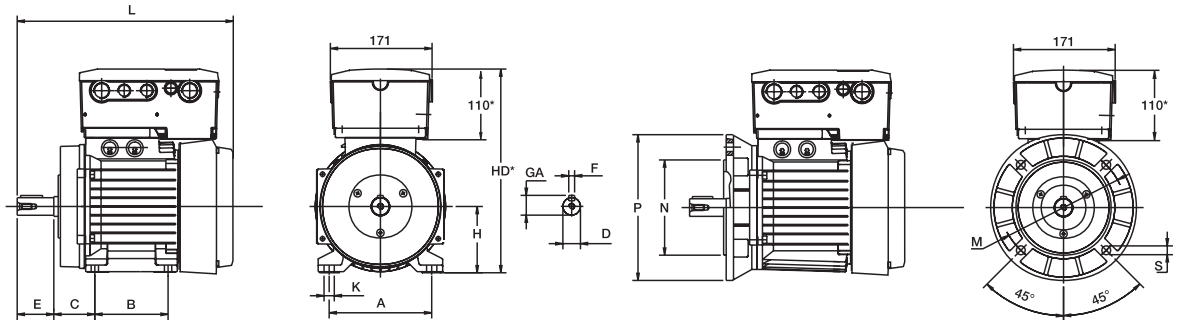

Motor size	IM B3, IM 1001; IM B5, IM 3001					IM 1001, IM B3					IM B5, IM 3001					IM B14, IM 3601			
	D	GA	F	E	L	A	B	C	HD*	K	H	M	N	P	S	M	N	P	S
80	On request																		
90	24	27	8	50	320	140	125	56	294	10	90	165	130	200	12	115	95	140	8
100	28	31	8	60	358.5	160	140	63	319	12	100	215	180	250	15	130	110	160	8

* Dimensions for ACS 160 standard units (type A). If the ACS 160 is equipped with a filter, the height increases by 36 mm (type B).

M2VA/AA Motor Technical Data

The motors listed here are shown as examples only.
For the latest information on these and other motors,
please contact an ABB office or your local distributor.
Specifications subject to change without notice.



TEFC squirrel cage three-phase motors M2VA/AA IP 55 IC 411, insulation class F, temperature rise class B

Output Type kW designation	Product code	Speed r/min	Efficiency		Power factor FL cos φ	Current		Torque			Moment of inertia J=1/4 GD ² kgm ²	Weight kg	Sound pressure level LP dB(A)	ACS 160 type code ¹⁾²⁾	
			Full load 100%	3/4 load 75%		I _N A	I _S A	T _N Nm	T _S T _N	T _{max} T _N					
2-pole = 3000 r/min 400 V, 50 Hz															
0.55 M2VA 71B	3GVA 071 002-••A	2830	79.2	78.2	0.78	1.39	5.7	1.86	3.6	3.7	0.00128	6.5	58	ACS 163-1K1-3-A/-B	
0.75 M2VA 80A	3GVA 081 001-••A	2870	81.2	79.3	0.75	1.80	6.2	2.49	2.9	3.6	0.000722	9	60	ACS 163-1K6-3-A/-B	
1.1 M2VA 80B	3GVA 081 002-••A	2850	82.2	80.3	0.78	2.50	6.1	3.69	2.3	3.5	0.000763	11	60	ACS 163-2K1-3-A/-B	
1.5 M2AA 90S	3GAA 091 001-••A	2870	80.1	80.8	0.82	3.35	5.5	5.0	2.4	3.0	0.0019	13	63	ACS 163-2K7-3-A/-B	
2.2 M2AA 90L	3GAA 091 002-••A	2880	83.6	83.3	0.87	4.55	7.0	7.5	2.7	3.0	0.0024	16	63	ACS 163-4K1-3-A/-B	
4-pole = 1500 r/min 400 V, 50 Hz															
0.55 M2VA 80A	3GVA 082 001-••A	1390	75.3	73.1	0.71	1.55	4.6	3.78	2.6	2.9	0.001257	9	50	ACS 163-1K1-3-A/-B	
0.75 M2VA 80B	3GVA 082 002-••A	1400	78.2	75.6	0.66	2.15	4.7	5.12	3.5	3.9	0.001565	10.5	50	ACS 163-1K6-3-A/-B	
1.1 M2AA 90S	3GAA 092 001-••A	1410	77.5	78.2	0.81	2.59	5.0	7.5	2.2	2.7	0.0032	13	50	ACS 163-2K1-3-A/-B	
1.5 M2AA 90L	3GAA 092 002-••A	1420	80.3	80.2	0.79	3.45	5.0	10.0	2.4	2.9	0.0043	16	50	ACS 163-2K7-3-A/-B	
2.2 M2AA 100LA	3GAA 102 001-••A	1430	83.0	82.5	0.81	4.80	5.5	15.0	2.4	2.9	0.0069	21	64	ACS 163-4K1-3-A/-B	
6-pole = 1000 r/min 400 V, 50 Hz															
0.55 M2VA 80B	3GVA 083 002-••A	900	73.3	71.9	0.64	1.72	3.4	5.85	2.9	3.1	0.002176	10	47	ACS 163-1K1-3-A/-B	
0.75 M2AA 90S	3GAA 093 001-••A	930	71.5	72.3	0.67	2.36	4.0	7.5	1.9	2.3	0.0032	13	44	ACS 163-1K6-3-A/-B	
1.1 M2AA 90L	3GAA 093 002-••A	930	74.4	74.2	0.69	3.25	4.0	11.0	1.9	2.3	0.0043	16	44	ACS 163-2K1-3-A/-B	
1.5 M2AA 100L	3GAA 103 001-••A	950	80.0	78.3	0.71	3.92	4.5	15.0	1.9	2.3	0.0082	23	49	ACS 163-2K7-3-A/-B	

¹⁾ -A = standard, -B = with built-in filter

²⁾ ACS 160 types are selected according to the Continuous output current I_{2N}, see page 27.

Dimensions with ACS 160

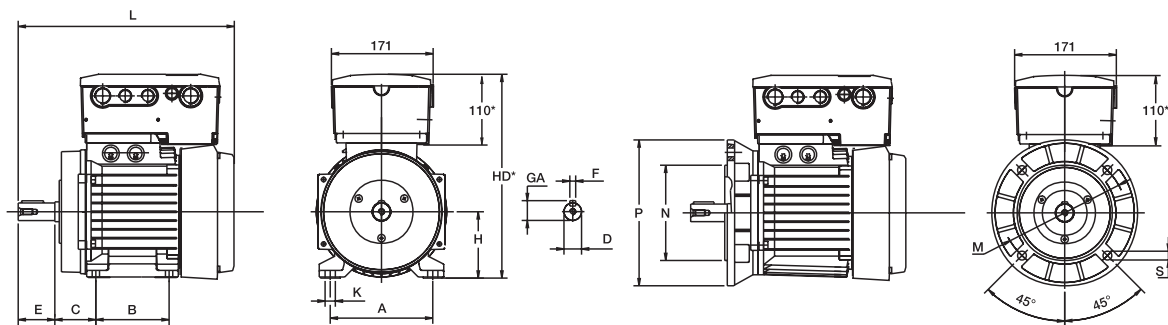

Motor size	IM B3, IM 1001; IM B5, IM 3001					IM 1001, IM B3					IM B5, IM 3001					IM B14, IM 3601			
	D	GA	F	E	L	A	B	C	HD*	K	H	M	N	P	S	M	N	P	S
71	14	16	5	30	238	112	90	45	259	7	71	130	110	160	10	85	70	105	6
80	19	21.5	6	40	265	125	100	50	272	10	80	165	130	200	12	100	80	120	6
90S	24	27	8	50	295	140	100	56	294	10	90	165	130	200	12	115	95	140	8
90L	24	27	8	50	320	140	125	56	294	10	90	165	130	200	12	115	95	140	8
100	28	31	8	60	358.5	160	140	63	319	12	100	215	180	250	15	130	110	160	8

* Dimensions for ACS 160 standard units (type A). If the ACS 160 is equipped with a filter, the height increases by 36 mm (type B).

Brake Motor Technical Data

The motors listed here are shown as examples only.
For the latest information on these and other motors,
please contact an ABB office or your local distributor.
Specifications subject to change without notice.

TEFC squirrel cage three-phase brake motors IP 55 IC 411, insulation class F, temperature rise class B

Output kW	Type designation	Product code	Speed r/min	Efficiency	Power factor	Current		Torque • rated breaking			c/h ¹⁾	Moment of inertia J=1/4 GD ² kgm ²	Weight kg	ACS 160 type code ^{2) 3)}	
				FL 100%	cos φ	I _N A	I _s /I _N	T _N Nm	T _B Nm	T _s /T _N					T _B /T _N
2-pole = 3000 r/min		400 V, 50 Hz													
a.c. 0.55	M3VRS 71B	3GVR 071 452-••A	2830	79.2	0.78	1.39	5.7	1.9	12	3.6	6.5	2600	0.00060	8	ACS 163-1K1-3-A/-B
0.75	M3VRS 80A	3GVR 081 451-••A	2870	81.2	0.75	1.8	6.2	2.5	18	2.9	7.2	2000	0.00074	11	ACS 163-1K6-3-A/-B
1.1	M3VRS 80B	3GVR 081 452-••A	2850	82.2	0.78	2.5	6.1	3.7	18	2.3	4.9	2000	0.00078	12	ACS 163-2K1-3-A/-B
1.5	M3ARS 90S	3GAR 091 451-••C	2870	82.0	0.82	3.3	5.5	5.0	35	2.4	7.0	1300	0.00210	19	ACS 163-2K7-3-A/-B
2.2	M3ARS 90L	3GAR 091 452-••C	2880	83.6	0.87	4.4	7.0	7.5	35	2.7	4.7	1200	0.00260	22	ACS 163-4K1-3-A/-B
d.c. 0.55	M3VRF 71B	3GVR 071 402-••A	2830	79.2	0.78	1.39	5.7	1.9	12	3.6	6.5	2600	0.00060	8	ACS 163-1K1-3-A/-B
0.75	M3VRF 80A	3GVR 081 401-••A	2870	81.2	0.75	1.8	6.2	2.5	18	2.9	7.2	2000	0.00074	11	ACS 163-1K6-3-A/-B
1.1	M3VRF 80B	3GVR 081 402-••A	2850	82.2	0.78	2.5	6.1	3.7	18	2.3	4.9	2000	0.00078	12	ACS 163-2K1-3-A/-B
1.5	M3ARF 90S	3GAR 091 401-••C	2870	82.0	0.82	3.3	5.5	5.0	35	2.4	7.0	1300	0.00210	19	ACS 163-2K7-3-A/-B
2.2	M3ARF 90L	3GAR 091 402-••C	2880	83.6	0.87	4.4	7.0	7.5	35	2.7	4.7	1200	0.00260	22	ACS 163-4K1-3-A/-B
4-pole = 1500 r/min		400 V, 50 Hz													
a.c. 0.55	M3VRS 80A	3GVR 082 451-••A	1390	75.3	0.71	1.55	4.6	3.8	18	2.6	4.7	5000	0.00128	11	ACS 163-1K1-3-A/-B
0.75	M3VRS 80B	3GVR 082 452-••A	1400	78.2	0.66	2.15	4.7	5.1	18	3.5	3.5	5000	0.00159	12	ACS 163-1K6-3-A/-B
1.1	M3ARS 90S	3GAR 092 451-••C	1410	79.0	0.79	2.6	5.0	7.5	35	2.2	4.7	3200	0.00340	19	ACS 163-2K1-3-A/-B
1.5	M3ARS 90L	3GAR 092 452-••C	1420	81.0	0.79	3.4	5.0	10.0	35	2.4	3.5	3200	0.00450	22	ACS 163-2K7-3-A/-B
2.2	M3ARS 100LA	3GAR 102 451-••C	1430	83.0	0.81	4.8	5.5	15.0	50	2.4	3.3	2700	0.00733	32	ACS 163-4K1-3-A/-B
d.c. 0.55	M3VRF 80A	3GVR 082 401-••A	1390	75.3	0.71	1.55	4.6	3.8	18	2.6	4.7	5000	0.00128	11	ACS 163-1K1-3-A/-B
0.75	M3VRF 80B	3GVR 082 402-••A	1400	78.2	0.66	2.15	4.7	5.1	18	3.5	3.5	5000	0.00159	12	ACS 163-1K6-3-A/-B
1.1	M3ARF 90S	3GAR 092 401-••C	1410	79.0	0.79	2.6	5.0	7.5	35	2.2	4.7	3200	0.00340	19	ACS 163-2K1-3-A/-B
1.5	M3ARF 90L	3GAR 092 402-••C	1420	81.0	0.79	3.4	5.0	10.0	35	2.4	3.5	3200	0.00450	22	ACS 163-2K7-3-A/-B
2.2	M3ARF 100LA	3GAR 102 401-••C	1430	83.0	0.81	4.8	5.5	15.0	50	2.4	3.3	2700	0.00733	32	ACS 163-4K1-3-A/-B
6-pole = 1000 r/min		400 V, 50 Hz													
a.c. 0.55	M3VRS 80B	3GVR 083 452-••A	900	73.3	0.64	1.7	3.4	5.9	18	2.9	3.1	7000	0.00220	12	ACS 163-1K1-3-A/-B
0.75	M3ARS 90S	3GAR 093 451-••C	930	74.0	0.67	2.2	4.0	7.5	35	1.9	4.7	3800	0.00340	19	ACS 163-1K6-3-A/-B
1.1	M3ARS 90L	3GAR 093 452-••C	930	77.0	0.69	3.13	4.0	11.0	35	1.9	3.2	3900	0.00450	22	ACS 163-2K1-3-A/-B
1.5	M3ARS 100L	3GAR 103 451-••C	950	80.0	0.71	3.92	4.5	15.0	50	1.9	3.3	3300	0.00863	34	ACS 163-2K7-3-A/-B
d.c. 0.55	M3VRF 80B	3GVR 083 402-••A	900	73.3	0.64	1.7	3.4	5.9	18	2.9	3.1	7000	0.00220	12	ACS 163-1K1-3-A/-B
0.75	M3ARF 90S	3GAR 093 401-••C	930	74.0	0.67	2.2	4.0	7.5	35	1.9	4.7	3800	0.00340	19	ACS 163-1K6-3-A/-B
1.1	M3ARF 90L	3GAR 093 402-••C	930	77.0	0.69	3.13	4.0	11.0	35	1.9	3.2	3900	0.00450	22	ACS 163-2K1-3-A/-B
1.5	M3ARF 100L	3GAR 103 401-••C	950	80.0	0.71	3.92	4.5	15.0	50	1.9	3.3	3300	0.00863	34	ACS 163-2K7-3-A/-B

¹⁾ No-load (shaft-free) operations/hour

²⁾ -A = standard, -B = with built-in filter

³⁾ ACS 160 types are selected according to the Continuous output current I_{2N}, see page 27.

Dimensions M3VRF/S or M3ARF/S with ACS 160

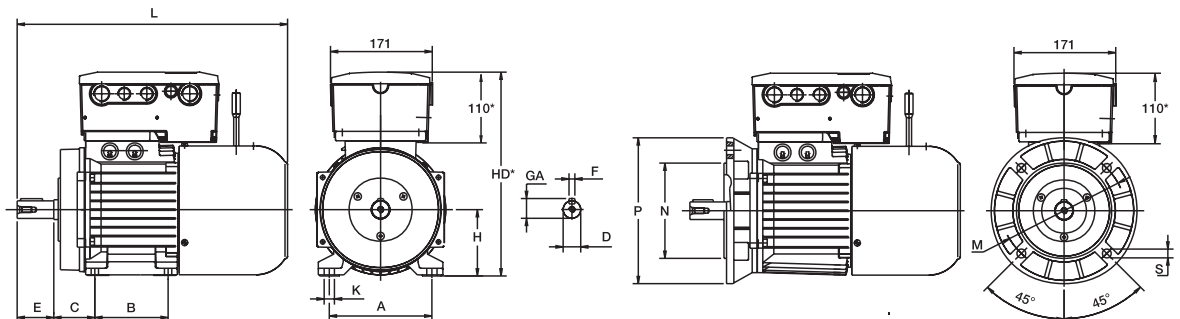

Motor size	IM B3, IM 1001; IM B5, IM 3001					IM 1001, IM B3						IM B5, IM 3001				IM B14, IM 3601			
	D	GA	F	E	L	A	B	C	HD*	K	H	M	N	P	S	M	N	P	S
71	14	16	5	30	316	112	90	45	259	7	71	130	110	160	10	85	70	105	6
80	19	21.5	6	40	360	125	100	50	272	10	80	165	130	200	12	100	80	120	6
90S	24	27	8	50	395	140	100	56	294	10	90	165	130	200	12	115	95	140	8
90L	24	27	8	50	395	140	125	56	294	10	90	165	130	200	12	115	95	140	8
100	28	31	8	60	453	160	140	63	318	12	100	215	180	250	15	130	110	160	8

* Dimensions for ACS 160 standard units (type A). If the ACS 160 is equipped with a filter, the height increases by 36 mm (type B).

ACS 400 Standard Drive

2.2 - 37 kW Supply Voltage 380 - 480 V

Unique features

- Wide power range up to 37 kW
- IP 21 and IP 54 variations
- Text display
- Built-in fieldbus protocols

More value for money

- Built-in EMC filtering
- Output extension module
- Good protection for motor and processes
- Wide variety of fieldbus protocols
- Simple and reliable

efesotomasyon.com

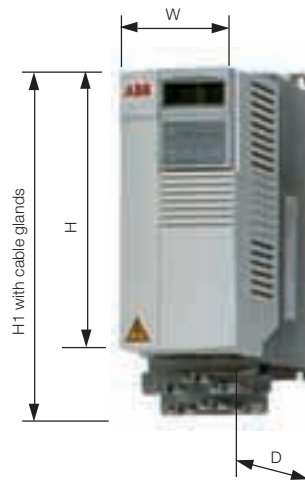

Dimensions

Units with IP 21 enclosures

Unit type IP 21	W	H	H1 with cable glands	D	Weight
	mm	mm	mm	mm	kg
ACS 401-0004	125	330	373	209	5.8
ACS 401-0005	125	330	373	209	5.8
ACS 401-0006	125	330	373	209	5.8
ACS 401-0009	125	430	473	221	9.0
ACS 401-0011	125	430	473	221	9.0
ACS 401-0016	203	545	586	248	18.5
ACS 401-0020	203	545	586	248	18.5
ACS 401-0025	203	636	686	280	27.0
ACS 401-0030	203	636	686	280	27.0
ACS 401-0041	203	636	686	280	27.0

Dimensions

Units with IP 54 enclosures

Unit type IP 54	W	H ¹⁾	D	Weight
	mm	mm	mm	kg
ACS 401-0004	215	453	240	7.2
ACS 401-0005	215	453	240	7.2
ACS 401-0006	215	453	240	7.2
ACS 401-0009	215	551	253	11.2
ACS 401-0011	215	551	253	11.2
ACS 401-0016	257	642	280	22.3
ACS 401-0020	257	642	280	22.3
ACS 401-0025	257	742	312	32.3
ACS 401-0030	257	742	312	32.3
ACS 401-0041	257	742	312	32.3

¹⁾ In IP 54 units cable glands are inside the enclosure.



ACS 400 Technical Specification

Mains connection

Power range: 2.2 - 37 kW

Voltage: 3-phase, 380 to 480 V, $\pm 10\%$

Frequency: 48 to 63 Hz

Power Factor: 0.98

Motor connection

Voltage: 3-phase, from 0 to U_{SUPPLY}

Frequency: 0 to 250 Hz

Continuous loading capability (constant torque at a max. ambient temperature of 40°C): Rated output current I_2 .

Overload capacity (at a max. ambient temp. of 40°C):

- at constant torque $1.5 \times I_{2N}$, for 1 minute every 10 minutes
- at constant torque $1.25 \times I_{2N}$, for 2 minutes every 10 minutes

Characteristic data for short-time, intermittent and periodic load cycles are available on request.

Switching frequency:

Standard 4 kHz, Low-noise: 8 kHz

Acceleration time: 0.1 to 1800 s

Deceleration time: 0.1 to 1800 s

Programmable control connections

Two analog inputs:

- Voltage signal: 0 (2) to 10 V, 200 k Ω single-ended
- Current signal: 0 (4) to 20 mA, 500 Ω single-ended
- Potentiometer reference value:
10 V $\pm 2\%$ max. 10 mA, $1 \text{ k}\Omega \leq R \leq 10 \text{ k}\Omega$
- Response time: $\leq 60 \text{ ms}$
- Resolution: 0.1%
- Accuracy: $\pm 1\%$

One analog output: 0 (4) to 20 mA, load $< 500 \Omega$

Auxiliary voltage: 24 V, max. 250 mA

Five digital inputs:

- 12 V... 24 V DC with internal or external supply, PNP and NPN
- Input impedance: 1.5 k Ω
- Response time: $\leq 9 \text{ ms}$

Two relay outputs:

- Switching voltage: 12 to 250 V AC or max 30 V DC/0.5 A
- Maximum continuous current: 10 mA to 2 A

Serial communication for the control panel or external control: Modbus protocol

Protection limits

Overvoltage:

- Running V DC: 842 (corr. to 595 V input)
- Start inhibit V DC: 661 (corr. to 380 - 415 V input)
765 (corr. to 440 - 480 V input)

Undervoltage:

- Running V DC: 333 (corr. to 247 V input)
- Start inhibit V DC: 436 (corr. to 380 - 415 V input)
505 (corr. to 440 - 480 V input)

Environmental limits

Ambient temperatures:

- Output current = I_2 , $f_{\text{switch}} = 4 \text{ kHz}$: 0 to 40°C
- Output current = $0.9 \cdot I_2$, $f_{\text{switch}} = 4 \text{ kHz}$: 40 to 50°C
- Output current = $0.8 \cdot I_2$, $f_{\text{switch}} = 8 \text{ kHz}$: 0 to 40°C

Altitude:

- Output current = I_2 : 0 to 1000 m
- Output current reduced by 1% per 100 m over 1000 m to 2000 m

Relative humidity: lower than 95% (without condensation)

Protection class: IP 21 or IP 54

Paint colour: NCS 1502-Y, RAL 9002, PMS 420 C

Contamination levels: no conductive dust, corrosive liquids or gases (IEC 721-3-3).

Product compliance

- Low Voltage Directive 73/23/EEC with supplements
- EMC Directive 89/336/EEC with supplements
- Quality assurance system ISO 9001 and ISO 14001
- CE, UL, ULc and C-Tick approvals

Options

- Control panel ACS-PAN-A
- Control panel ACS 100 - PAN
- Extension cable 3 m with IP 65 Kit for control panels PEC-98-0008
- RS 485/232 adapter
- DriveWindow Light 2
- DDCS adapter for fieldbus modules
- ACS 400 Extended Output Option Module
- Fieldbus modules
- Embedded fieldbus protocols (Modbus, N2)
- EMC input filters are required only in 1st Environment
- Braking units and choppers
- Input and output chokes
- Flange mounting kits for IP 21 units

ACS 400 Technical Data

2.2 kW - 37 kW Supply Voltage 380 - 480 V ± 10%

Type code	Frame size	Squared torque ratings				Constant torque ratings				Over-current limit (peak)	Max. motor cable length ⁵⁾ fsw = 4 kHz fsw = 8 kHz m	Line fuse ¹⁾ A	Power losses	
		Nominal motor P _{NSQ} ³⁾ Squared torque kW	Input current I _{1NSQ} A	Cont. output current I _{2NSQ} ²⁾ A	110% I _{2NSQ} ⁶⁾ A	Nominal motor P _N ³⁾ Constant torque kW	Input current I _{1N} A	Cont. output current I _{2N} ²⁾ A	150% I _{2N} ⁷⁾ A				Power circuit W	Control circuit W
ACS 401-0004-3-X	R1 ⁴⁾	3.0	6.2	6.6	7.3	2.2	4.7	4.9	7.4	20.3	100/50	10	90	6
ACS 401-0005-3-X	R1 ⁴⁾	4.0	8.3	8.8	9.7	3.0	6.2	6.6	9.9	27.5	100/50	10	120	6
ACS 401-0006-3-X	R1 ⁴⁾	5.5	11.1	11.6	12.8	4.0	8.8	8.8	13.2	37	100/50	16	170	6
ACS 401-0009-3-X	R2 ⁴⁾	7.5	14.8	15.3	16.8	5.5	11.1	11.6	17.4	48	200/100	16	230	6
ACS 401-0011-3-X	R2 ⁴⁾	11	21.5	23	25.3	7.5	14.8	15.3	23	64	200/100	25	330	6
ACS 401-0016-3-X	R3 ⁴⁾	15	29	30	33	11	21.5	23	34	76	200/100	35	450	6
ACS 401-0020-3-X	R3 ⁴⁾	18.5	35	38	42	15	29	30	45	99	200/100	50	560	6
ACS 401-0025-3-X	R4 ⁴⁾	22	41	44	48	18.5	35	38	57	125	200/100	50	660	6
ACS 401-0030-3-X	R4 ⁴⁾	30	56	59	65	22	41	44	66	145	200/100	60	900	6
ACS 401-0041-3-X	R4 ⁴⁾	37	68	72	79	30	56	59	88	195	200/100	80	1100	6

¹⁾ Fuse type: UL class CC or T. For non-UL installations IEC269 gG. Use 60°C rated power cable (75°C if T_{amb} above 45°C).

²⁾ Power stages are designed for continuous I_{2N}/I_{2NSQ} current. These values apply at altitudes of less than 1000 m ASL.

³⁾ P_{NSQ}/P_N rated motor power. The power ratings in kW apply to most 2- and 4-pole IEC 34 motors. The current ratings are the same regardless of the supply voltages. The rated current of the ACS 400 must be higher than or equal to the rated motor current to achieve the rated motor power given in the table. P_{NSQ}: Pump and fan applicable values (squared torque). P_N: Other applications (constant torque values).

⁴⁾ For dimensions and weight see page 35.

⁵⁾ If a longer motor cable is required, use output choke, see page 43. If 1st Environment EMC performance is required, see page 42.

⁶⁾ 110% I_{2NSQ} short term overload current allowed for one minute every 10 minutes.

⁷⁾ 150% I_{2N} short term overload current allowed for one minute every 10 minutes.

Use 60°C rated power cable (75°C if T_{amb} above 45°C). Follow local rules for cable cross-sections. Shielded motor cable is recommended.

Max. wire sizes/Power terminals (mm², stranded)

- R1, R2 10 (AWG 6)/torque 1.3 - 1.5 Nm
- R3 16 (AWG 4)/torque 1.5 - 1.8 Nm
- R4 35 (AWG 2)/torque 3.2 - 3.7 Nm

Max. wire sizes/Control terminals (mm²)

- 0.5-1.5 (AWG 22...AWG 16)/torque 0.4 Nm

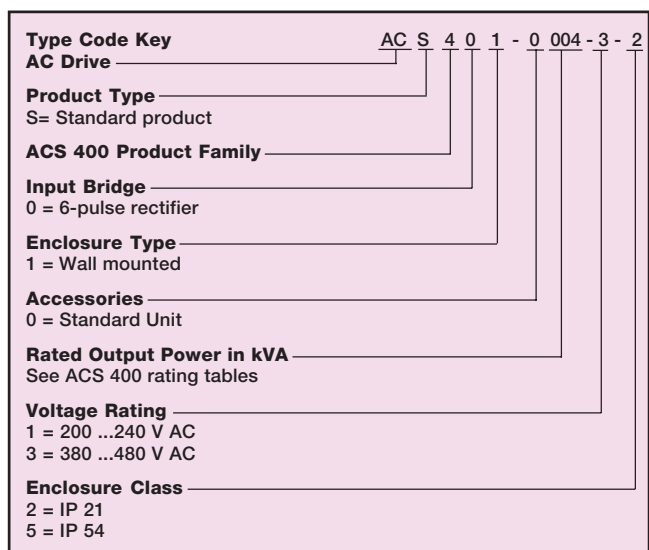

ACS 400 Connection Examples

These connections are shown as examples only.
Please refer to the ACS 400 User's Manual for more detailed information.

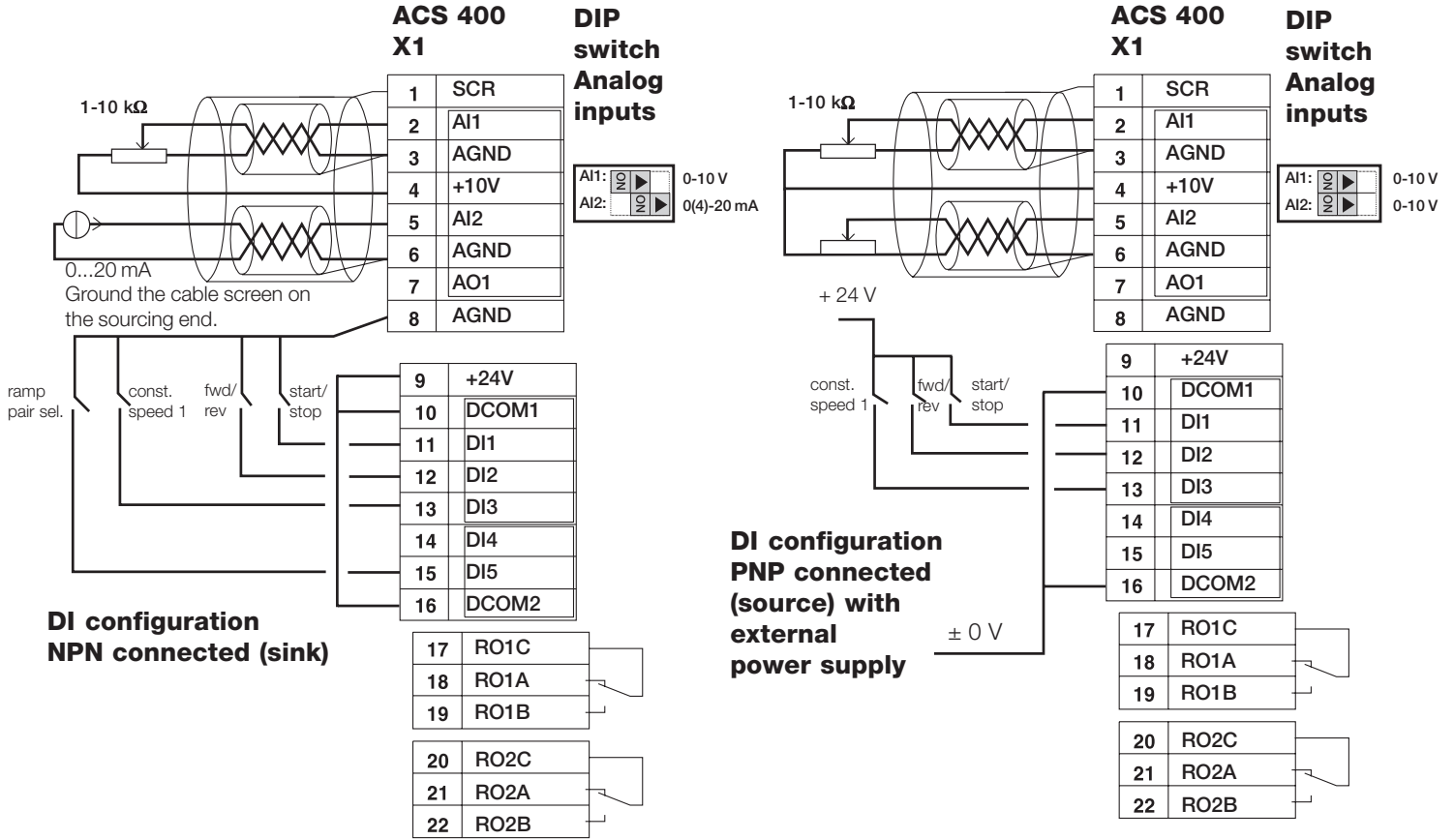

RS 485 Multidrop application

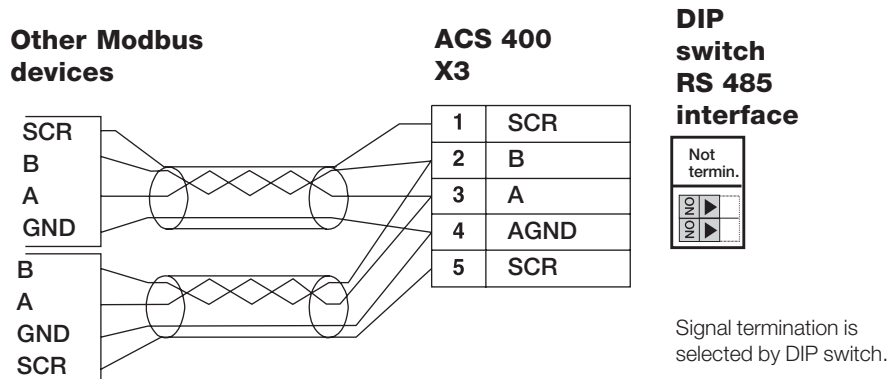

ACS 400 Options



Control panels

Type code: ACS-PAN-A

For very easy programming of ACS 400, ACS-PAN-A a detachable multi-lingual alphanumeric control panel, can be used. The control panel has a bright LDC display to make the reading of parameters easy. The control panel can also be used for copying parameters between ACS 400 drives.

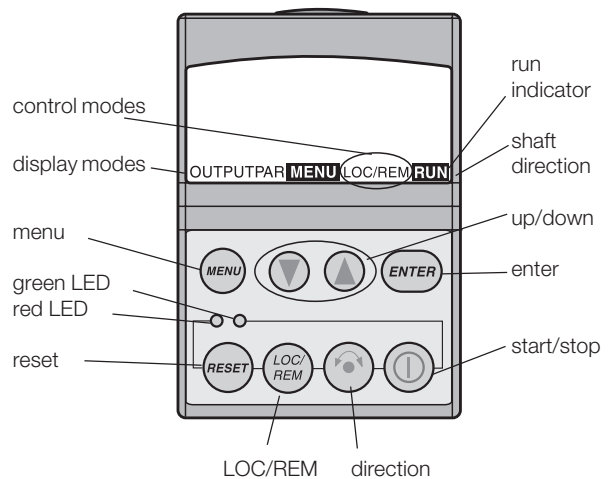

Type code: ACS 100 - PAN

The ACS 100 - PAN can also be used with the ACS 400. With this panel parameters can be copied and downloaded and their values can be set. The panel has a numerical display.

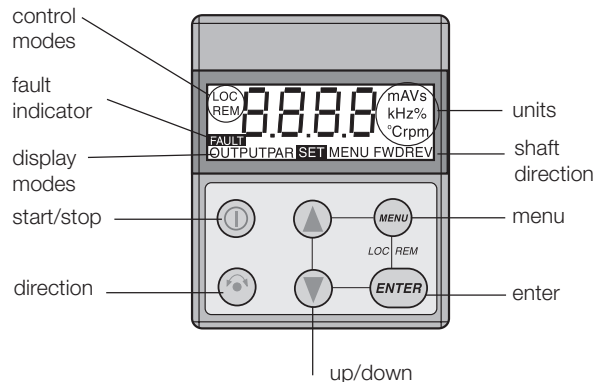

ACS 400 Options

Panel Extension Cable Kit

Type code: PEC-98-0008

This option includes a gasket, a 3 m connection cable for control panels, fixing material for the cables and a drilling jig. With this kit IP 65 protection class is achieved.

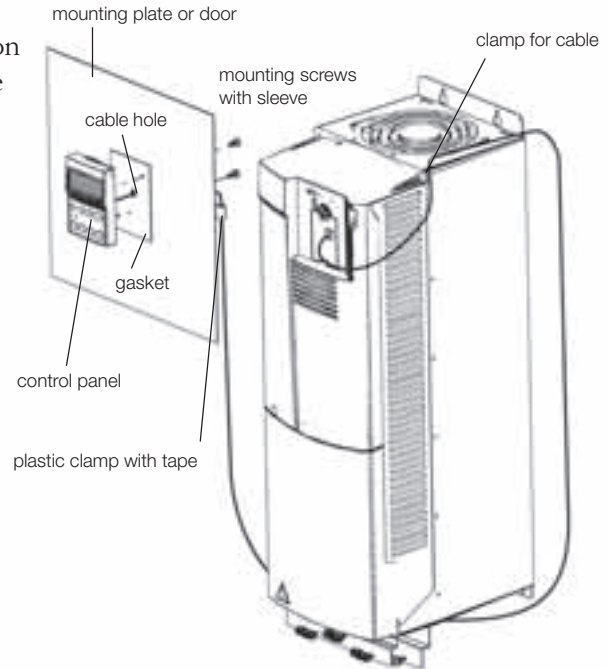

ACS 140 RS 485/232 adapter for the ACS 400

Type code: ACS 140 RS 485/232

The ACS 400 offers the RS 485 connection as standard. ACS 140 RS 485/232 is needed with the ACS 400 only when using the DriveWindow Light 2 start-up and maintenance tool. When the adapter is used it replaces the control panel. For more information on DriveWindow Light 2, please refer to page 46.

efesotomasyon.com

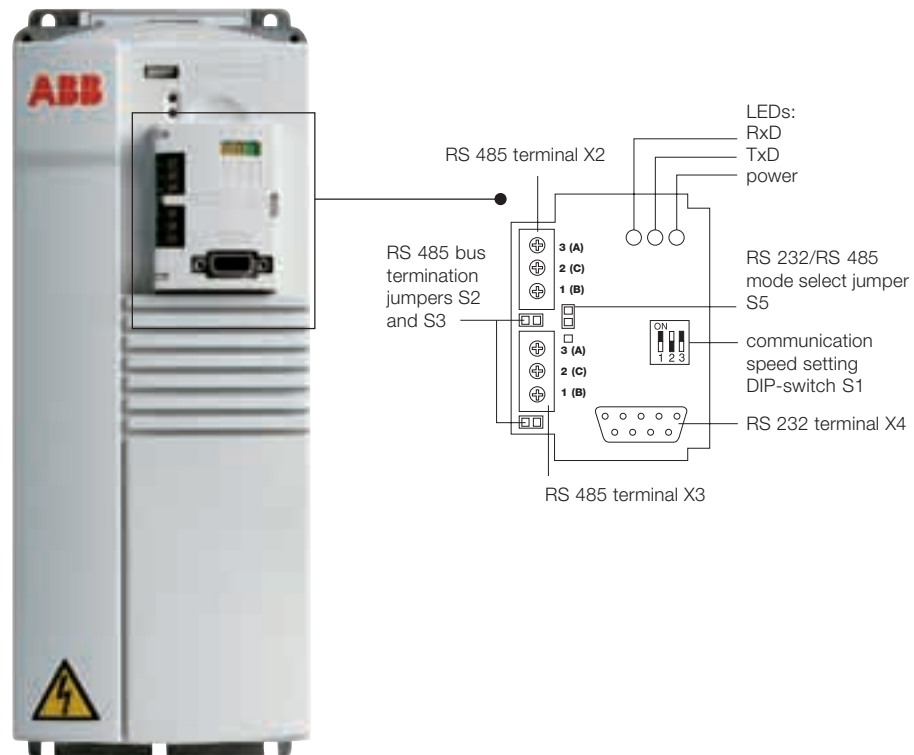

ACS 400 Options

Fieldbus Control

ABB AC drives can connect to all major automation systems. This is achieved with a dedicated fieldbus concept between the fieldbus systems and the ABB Distributed Drive Communication System (DDCS). DDCS is a high speed optical link combining fast data transfer and excellent noise immunity.

The wide range of fieldbuses means that the automation system can be chosen independently of the AC drives.

Built-in fieldbuses

ACS 400 comes with a built-in Modbus protocol. This Modbus can be replaced by Johnson Controls' N2 protocol. In this case please contact your ABB distributor.

External fieldbus modules

The table below lists the external fieldbus modules which can be used with the ACS 400. An ACS 400-DDCS adapter is required to connect these fieldbuses with the drive.

Fieldbus technical data

Fieldbus	Type	Protocol mode	Device profile	Baudrate (min.-max.)
Profibus	NPBA-12	DP, DPV1	Adjustable Speed Drives	12 Mbit/s
InterBus-S	NIBA-01	I/O, PCP	ABB Drives	500 kbit/s
Modbus	NMBA-01	RTU	ABB Drives	1.2-19.2 kbit/s
Modbus Plus ¹⁾	NMBP-01	N.A.	ABB Drives	1000 kbit/s
DeviceNet	NDNA-02	N.A.	AC Drives, DC Drives	125-500 kbit/s
CANopen ²⁾	NCAN-02	N.A.	Drives and Motion Control	1000 kbit/s
LonWORKS [®]	NLON-01	LonTalk [®]	Variable Speed Motor Drive	78 kbit/s
ABB CS 31	NCSA-01	Word, Binary	ABB Drives	187.5 kbit/s
ABB AF100	NAFA-01	N.A.	ABB Drives	1500 kbit/s
FLN/N2	NBAA-01	FLN	ABB Drives	1.2-19.2 kbit/s
		N2	ABB Drives	9.6 kbit/s

¹⁾ Software version 1.3 or later is compatible with the ACS 400.

²⁾ Fieldbus module version 1.2 or later is compatible with the ACS 400.

N.A. = Not Applicable



Fieldbus module technical specification

Power supply

Supply voltage: 24 V DC ±10%
Current consumption: 60..160 mA

Connections

Bus-line: Screw terminals
Drive link: Fibre optics

Environmental limits

Ambient temperature: 0..50°C
Altitude: up to 2000 m ASL

Enclosure

Degree of protection: IP 20

Drive interface

Protocol: DDCS
Baudrate: 4 Mbit/s

ABC fieldbus modules

Type codes: ABC-PDP and ABC-DEV

Up to ten drives can be controlled with one ABC fieldbus module. The drives may be of type ACS 140, ACS 160 and/or ACS 400. ABC modules are available for Profibus (type code ABC-PDP) and DeviceNet (type code ABC-DEV) fieldbus protocols. The module is DIN rail mountable with protection class IP 20. The ABC module requires 24 V DC power supply and provides an RS 485 Modbus interface for communication with the drives. The response time on the Modbus network is approximately 200 ms per drive.

ACS 400 Options

DDCS adapter for the ACS 400

Type code: ACS 400-DDCS

The DDCS adapter offers a fibre optic connection to the ACS 400 through ABB internal DDCS-protocol. All the fieldbus adapters are connected to the ACS 400 using this high speed connection. The DDCS adapter can be fitted inside units with both IP 21 and IP 54 degree of protection.



ACS 400 Extended Output Option Module

Type code: EXTIO-01-KIT

In case the ACS 400 standard I/O's are not sufficient, an extended output option module can be used.

This plug-in option offers two additional relay outputs and one analog output. Furthermore it offers a DDCS link, for example, for a fieldbus connection. This option can only be fitted inside a unit with IP 54 degree of protection.

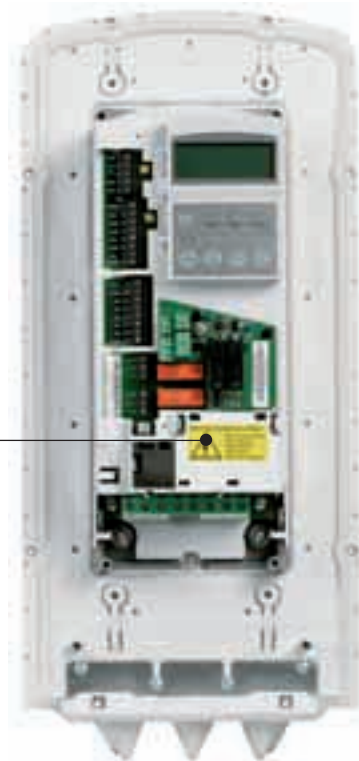

ACS 400 Options

EMC Filters Series

The ACS 400 complies with the limits for EN61800-3 2nd Environment restricted distribution as standard. To comply with the limits for EN61800-3 1st Environment, restricted distribution, optional EMC filters can be used.

Selection table and dimensions for IP 20 EMC filters

Type code	EMC filter type	A mm	B mm	C		D mm	Max. motor cable length m	
				IP 21 mm	IP 54 mm		Switching Frequency 4 kHz	8 kHz
ACS 401-0004-3	ACS 400-IF11-3	120	378	269	300	60	100	-
ACS 401-0005-3	ACS 400-IF11-3	120	378	269	300	60	100	-
ACS 401-0006-3	ACS 400-IF11-3	120	378	269	300	60	100	-
ACS 401-0009-3	ACS 400-IF21-3	120	477	281	313	60	100	100
ACS 401-0011-3	ACS 400-IF21-3	120	477	281	313	60	100	100
ACS 401-0016-3	ACS 400-IF31-3	170	350	-	-	80	100	100
ACS 401-0020-3	ACS 400-IF31-3	170	350	-	-	80	100	100
ACS 401-0025-3	ACS 400-IF41-3	200	400	-	-	80	100	100
ACS 401-0030-3	ACS 400-IF41-3	200	400	-	-	80	100	100
ACS 401-0041-3	ACS 400-IF41-3	200	400	-	-	80	100	100

Always use RFI Ferrite ACS-CHK-C with series ACS400 IF41-3 EMC filters. The motor cable including the shield must be fed through the hole in the ferrite. Ferrite ACS-CHK-C is supplied in the same package as the input filter.

Selection table and dimensions with IP 54 EMC filter covers

EMC filter type	IP 54 protection cover type	Cable diameter	E mm
ACS 400-IF11-3	IFC-99-001	9-16	max. 534
	IFC-99-002	13-20	
ACS 400-IF21-3	IFC-99-002	13-20	max. 633
	IFC-99-003	18-25	
ACS 400-IF31-3	IFC-99-004	13-20	max. 594
	IFC-99-005	18-25	
	IFC-99-006	25-31	
ACS 400-IF41-3	IFC-99-005	18-25	max. 644
	IFC-99-006	25-31	
	IFC-99-007	32-38	

The IP 54 EMC filter is made by using an IP 20 filter and two separate covers. The covers are installed on both ends of the IP 20 filter.

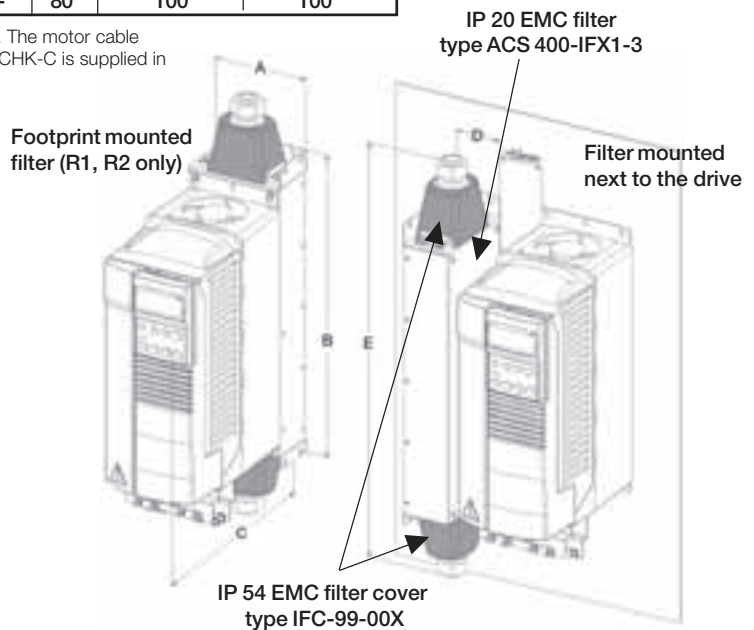

Dimensions with IP 21 EMC filter

Type code	A mm	B mm	C mm	D mm	Max. motor cable length fsw = 4 kHz, fsw = 8 kHz m	EMC filter type
ACS 401-0005-3	453	102	87	116	10	ACS 400-IF22-3
ACS 401-0006-3	453	102	87	116	10	ACS 400-IF22-3
ACS 401-0009-3	553	114	87	116	10	ACS 400-IF22-3
ACS 401-0011-3	553	114	87	116	10	ACS 400-IF22-3

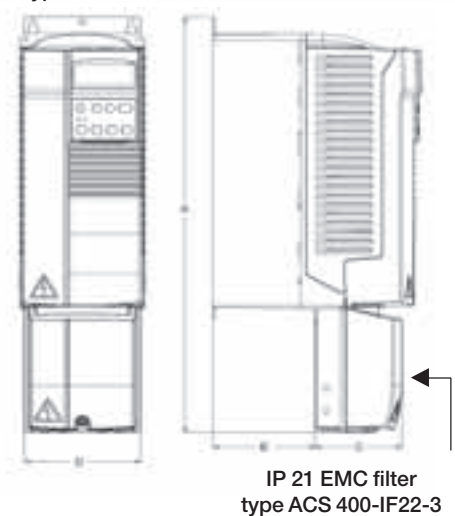

ACS 400 Options

Output Chokes

If there is no need to comply with the EN61800-3 EMC limits with the frequency converter, an optional NOCH-output choke can be used to achieve longer cable lengths. These chokes can also be used if an EMC plan is created between the customer and the sales person.

Selection table

Type code	Output choke type	Max. cable mm ²	I/A	Max. cable length with choke m ¹⁾	Max. cable length without choke m ¹⁾
ACS 401-0004-3	NOCH-0016-6X	10	15	150	100
ACS 401-0005-3	NOCH-0016-6X	10	15	150	100
ACS 401-0006-3	NOCH-0016-6X	10	15	150	100
ACS 401-0009-3	NOCH-0016-6X	10	15	250	200
ACS 401-0011-3	NOCH-0016-6X	10	15	250	200
ACS 401-0016-3	NOCH-0030-6X	16	28	250	200
ACS 401-0020-3	NOCH-0030-6X	16	28	250	200
ACS 401-0025-3	NOCH-0070-6X	35	65	300	200
ACS 401-0030-3	NOCH-0070-6X	35	65	300	200
ACS 401-0041-3	NOCH-0070-6X	35	65	300	200

¹⁾ Without EMC filter

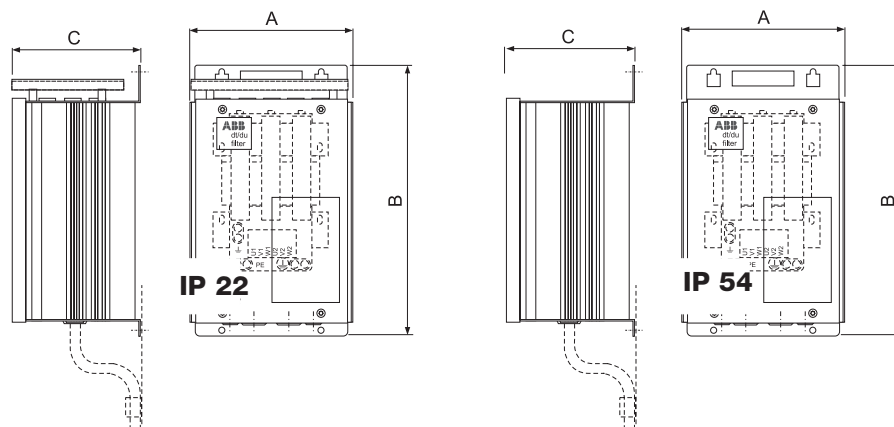

Dimensions

Choke type	A mm	B mm	C mm	Weight kg
NOCH-0016-62 (IP 22)	199	323	154	6
NOCH-0030-62 (IP 22)	249	348	172	9
NOCH-0070-62 (IP 22)	279	433	202	15.5
NOCH-0016-65 (IP 54)	199	323	154	6
NOCH-0030-65 (IP 54)	249	348	172	9
NOCH-0070-65 (IP 54)	279	433	202	15.5

Flange mounting kits for IP 21 units

The ACS 400 can be flange mounted to conduct heat dissipation away from the enclosure of the drive. Select the flange mounting kit according to the ACS 400 frame size. Flange mounting is available for IP 21 units only.

Selection table

ACS 400 frame size	Flange mounting kit type
R1	FMS-99-0001
R2	FMS-99-0002
R3	FMS-99-0003
R4	FMS-99-0004

Brake Options

Brake Units

Compact-sized brake units which include brake chopper and resistor, can be used with ACS 100, ACS 140 and ACS 400. For more information please refer to the ACS-BRK Break Units Installation and Start-up Guide.

Brake units technical data

Brake unit type code	Frequency converter input voltage	Resistor OHM	Continuous output W	Max. output 20 s W
ACS-BRK-A	200 – 240 V AC 380 – 480 V AC	400	150	350 1000
ACS-BRK-B	200 – 240 V AC 380 – 480 V AC	150	400	1000 2400
ACS-BRK-C	200 – 240 V AC 380 – 480 V AC	32	2000	4500 12000
ACS-BRK-D	200 – 240 V AC 380 – 480 V AC	10.5	7000	14000 42000
ACS-BRK-E	200 – 240 V AC –	4	5000	30000
ACS-BRK-F	200 – 240 V AC –	50	400	2400

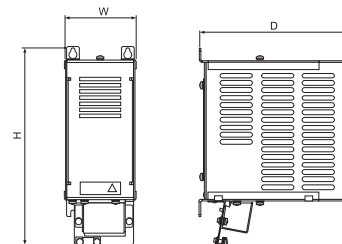

Dimensions

Brake unit type code	Width mm	Height mm	Depth mm	Weight kg
ACS-BRK-A	90	240	180	1.2
ACS-BRK-B	90	300	285	1.5
ACS-BRK-C	150	500	347	7.5
ACS-BRK-D	270	600	450	20.5
ACS-BRK-E	270	600	450	18.5
ACS-BRK-F	90	300	285	1.5

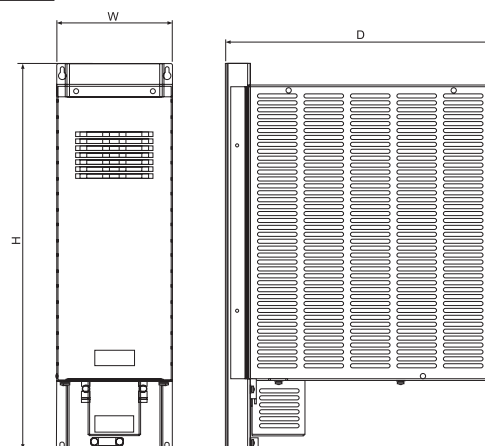

Brake Choppers

With a brake chopper the customer selects the resistor used. This ensures an optimum match between the equipment and the requirements.

Brake choppers technical data

Brake chopper type code	Frequency converter input voltage	Resistance OHM	Continuous output W	Max. output 20 s W
ACS-BRK-BL	200 - 240 V AC 380 - 480 V AC	150	400	1000 2400
ACS-BRK-CL	200 - 240 V AC 380 - 480 V AC	32	2000	4500 12000

Dimensions

Brake chopper type code	Width mm	Height mm	Depth mm
ACS-BRK-BL	93	250	75
ACS-BRK-CL	125	360	106.5



Start-up and Maintenance Tool

DriveWindow Light 2

DriveWindow Light 2

DriveWindow Light 2 is a set-up and control tool which is Win98, WinNT, Win2000 and WinXP compatible. DriveWindow Light 2 operates both off- and on-line. No additional PC hardware required. DriveWindow Light 2 uses the PC's RS 232 port and Modbus serial communication protocol. DriveWindow Light 2 is available also for some handheld computers.

ABB's DriveWindow Light 2 is an easy-to-use tool for the commissioning and controlling of drives. It provides even more flexibility and operating possibilities for ABB drives. It has features for programming, monitoring, trouble shooting and maintenance. It is also an excellent training tool. DriveWindow Light 2 operates with Low Voltage AC Drive types ACS 140, ACS 160, ACS 400 and DC drive DCS 400.

ACS 140 and ACS 400 drives have to be equipped with an ACS 140 RS 485/232 adapter and the ACS 160 has to be equipped with the CFB-RS adapter when DriveWindow Light 2 is used.

DriveWindow Light 2 is one of the start-up and maintenance tools in the Drive^{IT} suite.

DriveWindow Light 2 features

- Off- and on-line viewing and changing of drive parameters.
- Backup and restore parameters. In a fault situation the parameters can be reloaded resulting in time savings.
- Graphical monitoring of actual signal values.
- I/O mapping table
- Controlling of the drive



Contact and web information

The ABB Group's philosophy "Think Global, Act Local" means that no matter where you are, or where you need a Low Voltage AC Drive you can simply rely on ABB's worldwide presence.

ABB's worldwide presence is built on strong local companies working together with the local distributor and channel partner network across borders to achieve a uniform level of services for all our customers. By combining the experience and know-how gained in local and global markets,

we ensure that our customers in all industries can gain the full benefit from our products.

For further details about all our variable speed drive products and services please contact your nearest ABB distributor or visit the ABB website www.abb.com/motors&drives.

For orders, quotations, etc. please contact your local ABB Drives distributor, ABB office, or visit the website www.comp-ac.com.

Argentina (Valentin Alsina)

Tel: +54 (0)114 229 5707
Tel: 0800 2226 6722
Fax: +54 (0)114 229 5593

Australia (Victoria)

Tel: +61 3 9644 4100
Fax: +61 3 9647 9256

Austria (Vienna)

Tel: +43 1 60109-0
Tel: 0800 201 009
Fax: +43 1 60109-8312

Belarus (Minsk)

Tel: +375 172 236711
Tel: +375 172 239185
Fax: +375 172 239154

Belgium (Zaventem)

Tel: +32 2 718 6313
Fax: +32 2 718 6664

Brazil (Sao Paulo)

Tel: +55 11 3688 9282
Fax: +55 11 3684 1991

Bulgaria (Sofia)

Tel: +359 2 981 4533
Fax: +359 2 980 0846

Canada (Montreal)

Tel: +1 866 426 6722
Fax: +1 514 332 0609

Chile (Santiago)

Tel: +56 2 544 7100
Fax: +56 2 544 7405

China (Beijing)

Tel: +86 10 8456 6688
Fax: +86 10 8456 7636

Colombia (Bogota)

Tel: +57 1 417 8000
Fax: +57 1 413 4086

Croatia (Zagreb)

Tel: +385 1 2383 600
Fax: +385 1 2395 598

Czech Republic (Prague)

Tel: +420 2 2283 2111
Fax: +420 2 2283 2310

Denmark (Skovlunde)

Tel: +45 44 504 345
Fax: +45 44 504 365

Estonia (Tallinn)

Tel: +372 6 711 800
Fax: +372 6 711 810

Finland (Helsinki)

Tel: +358 10 22 24200
Tel: +358 10 22 21999
Fax: +358 10 22 22913

France (Champagne)

Tel: 0801 220 400
Fax: 0801 220 401

Germany (Mannheim)

Tel: 0800 2667 220
Tel: +49 (0)621 381 1741
Fax: +49 (0)621 381 1777

Great Britain (Manchester)

Tel: 0700 2 CompAC
Tel: +44 (0)700 2266 722
Fax: +44 161 445 6066

Greece (Athens)

Tel: +30 1 289 1800
Fax: +30 1 289 1899

Hungary (Budapest)

Tel: +36 1 443 2224
Fax: +36 1 443 2144

India (Bangalore)

Tel: +91 80 837 0416
Fax: +91 80 839 9173

Indonesia (Jakarta)

Tel: +62 21 590 9955
Fax: +62 21 590 0115
Fax: +62 21 590 0116

Ireland (Dublin)

Tel: +353 1 4057 300
Fax: +353 1 4057 312

Israel (Tirat Carmel)

Tel: +972 4 858 1188
Fax: +972 4 858 1199

Italy (Milano)

Tel: +39 02 2414 3792
Fax: +39 02 2414 3979

Latvia (Riga)

Tel: +371 7 063600
Fax: +371 7 063601

Lithuania (Vilnius)

Tel: +370 2 738 351
Fax: +370 2 738 333

Luxembourg (Leudelange)

Tel: +353 493 116
Fax: +352 492 859

Macedonia (Skopje)

Tel: +389 2 118 010
Fax: +389 2 118 774

Malaysia (Kuala Lumpur)

Tel: +60 3 5628 4888
Fax: +60 3 5631 2926

Mexico (Mexico City)

Tel: +52 5 328 1400
Fax: +52 5 329 1482

The Netherlands (Rotterdam)

Tel: +31 (0)10 407 8362
Fax: +31 (0)10 407 8433

New Zealand (Auckland)

Tel: +64 9 356 2170
Fax: +64 9 357 0019

Norway (Oslo)

Tel: +47 22 872 000
Fax: +47 22 872 900

Peru (Lima)

Tel: +51 1 561 0404
Fax: +51 1 561 3040

Philippines (Metro Manila)

Tel: +63 2 821 7777
Fax: +63 2 823 0309
Fax: +63 2 824 4637

Poland (Lodz)

Tel: +48 42 613 4900
Fax: +48 42 613 4901

Portugal (Amadora)

Tel: +35121 425 6239
Fax: +351 21 425 6392

Romania (Bucarest)

Tel: +40 1 310 4380
Fax: +40 1 310 4383

Russia (Moscow)

Tel: +7 095 956 9810
Fax: +7 095 956 3018

Saudi-Arabia (Al Khobar)

Tel: +966 (0)3 882 9394
Fax: +966 (0)3 882 4603

Singapore

Tel: +65 776 5711
Fax: +65 778 0222

Slovakia (Banska Bystrica)

Tel: +42 48 410 2324
Fax: +42 48 410 2325

Slovenia (Ljubljana)

Tel: +386 1 5875 482
Fax: +386 1 5875 495

South Africa (Johannesburg)

Tel: +27 11 617 2000
Fax: +27 11 908 2061

South Korea (Seoul)

Tel: +82 2 528 2794
Fax: +82 2 528 2338

Spain (Barcelona)

Tel: +34 (9)3 728 8700
Fax: +34 (9)3 728 8743

Sweden (Västerås)

Tel: +46 (0)21 32 93 00
Fax: +46 (0)21 32 93 01

Switzerland (Zürich)

Tel: +41 (0)1 435 6666
Fax: +41 (0)1 435 6605

Taiwan (Taipei)

Tel: +886 2 2577 6090
Fax: +886 2 2577 9467
Fax: +886 2 2577 9434

Thailand (Samuthprakarn)

Tel: +66 2 709 3346
Fax: +66 2 709 3765

Turkey (Istanbul)

Tel: +90 216 365 2900
Fax: +90 216 365 2944

USA (New Berlin)

Tel: +1 800 752 0696
Tel: +1 262 785 3200
Fax: +1 262 785 0397

Venezuela (Caracas)

Tel: +58 212 203 1799
Fax: +58 212 237 6270

Yugoslavia (Belgrad)

Tel: +381 11 324 4341
Fax: +381 11 324 1623



Drive^{IT} Low Voltage AC Drives

One call does it all

Telephone:
Your local distributor:



ABB Oy
Drives
P. O. Box 184
FIN - 00381 Helsinki
Finland
Telephone +358 10 22 11
Telefax +358 10 222 2877
eCommerce <http://www.comp-ac.com>